

Features

- Output power up to 75 W, 52 W/inch³
- Output voltage up to 400 VDC on request
- Operating case temperature -60 ... +110 °C
- Efficiency up to 88 %
- Case dimensions: 58x37x11 (mm) – V1
- CNC milled case
- Output voltage adjustment
- Remote ON/OFF
- Protection against reverse polarity (use AC inputs)
- Open-type mounting holes
- Inputs:
 - DC HV "300" (200-375 VDC, surge 400 VDC 100 ms)
 - DC HV "270" (155-375 VDC, surge 400 VDC 100 ms)
 - DC HV "150" (82-200 VDC, surge 230 VDC 100 ms)
 - AC 1ph. "115" (80-138 VAC, 113-195 VDC, surge 150 VAC 100 ms)
 - AC 1ph. "230" (187-264 VAC, 263-372 VDC, no surge)

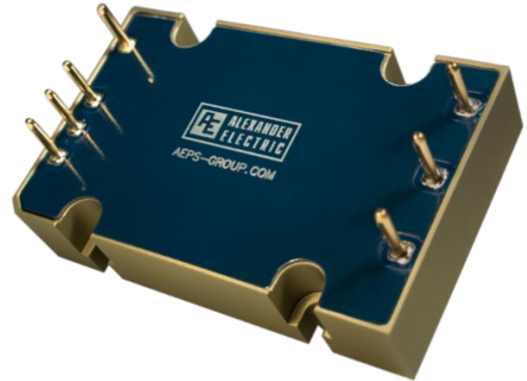

Description

JETDiV series of high voltage input AC/DC - DC/DC isolated converters with the open-type mounting holes meant for operation in harsh environmental conditions. The combination of electro-technical and mechanical parameters creates versatility for the series to be used in various application fields with strong vibrations and mechanical shocks: both low and high altitude in unprotected equipment compartments, in drones, in all types of transport, in supercomputers, in low and high temperature environments, digital signage equipment, in radar systems. The series is an optimal fit for any environment which requires low-profile, minimized dimensions and weight, high efficiency and wide temperature range.

Ordering information

JETDiV 75 - 300 S 60 - M - V1

1 2 3 4 5 6 7

- 1 Series name.
- 2 Nominal output power, W: default **75 W**, other output power limits may be provided on request.
- 3 Input voltage range: default **"300" 200-375 VDC**; possible to provide **"270"**, **"150"**, **"115"** and **"230"** ranges on request.
- 4 Number of output channels: **"S"** - 1 channel.
- 5 Nominal output voltage of channel.
- 6 Index of case operating temperature range: **"M"** - default **-60 ... +110 °C**; other temperature ranges possible on request.
- 7 Index of case form-factor.

Base models (1 channel) for "300" DC input					
Model part number	Input voltage	Output power	Output voltage	Output current per channel	Typical efficiency at 70 % load
JETDiV75-300S03.3-M-V1	DC HV "300" 200-375 VDC (300 VDC nom.) surge 400 VDC 100 ms	49.5 W	3.3 VDC	15 A	77 %
JETDiV75-300S05-M-V1		75 W	5 VDC	15 A	80 %
JETDiV75-300S12-M-V1		75 W	12 VDC	6.25 A	82 %
JETDiV75-300S15-M-V1		75 W	15 VDC	5 A	84 %
JETDiV75-300S24-M-V1		75 W	24 VDC	3.125 A	84 %
JETDiV75-300S27-M-V1		75 W	27 VDC	2.8 A	85 %
JETDiV75-300S36-M-V1		75 W	36 VDC	2.1 A	85 %
JETDiV75-300S48-M-V1		75 W	48 VDC	1.6 A	85 %
JETDiV75-300S60-M-V1		75 W	60 VDC	1.25 A	85 %
JETDiV75-300S120-M-V1		75 W	120 VDC	0.63 A	83 %
JETDiV75-300S200-M-V1		75 W	200 VDC	0.38 A	88 %

Base models (1 channel) for "230" 1ph. AC input					
Model part number	Input voltage	Output power	Output voltage	Output current per channel	Typical efficiency at 70 % load
JETDiV75-230S03.3-M-V1	AC 1ph. "230" 187-264 VAC (230 VAC nom.) no surge	49.5 W	3.3 VDC	15 A	77 %
JETDiV75-230S05-M-V1		75 W	5 VDC	15 A	80 %
JETDiV75-230S12-M-V1		75 W	12 VDC	6.25 A	82 %
JETDiV75-230S15-M-V1		75 W	15 VDC	5 A	84 %
JETDiV75-230S24-M-V1		75 W	24 VDC	3.125 A	84 %
JETDiV75-230S27-M-V1		75 W	27 VDC	2.8 A	85 %
JETDiV75-230S36-M-V1		75 W	36 VDC	2.1 A	85 %
JETDiV75-230S48-M-V1		75 W	48 VDC	1.6 A	85 %
JETDiV75-230S60-M-V1		75 W	60 VDC	1.25 A	85 %
JETDiV75-230S120-M-V1		75 W	120 VDC	0.63 A	83 %
JETDiV75-230S200-M-V1		75 W	200 VDC	0.38 A	88 %

Additional ordering information:

- 1) The units may be provided with a different range of input voltage on request, please see available ranges in our [selection guide](#).
- 2) Units with non-standard output voltage may be provided on request.
- 3) Units with non-standard output power may be provided on request.

General characteristics ³		
Switching frequency		200 kHz typ. (PWM modulation)
Temperature ranges	case operating temperature	-60 °C ... +110 °C (default "M")
	storage temperature	-60 °C ... +125 °C
Over-temperature protection		+110° C typ.
Thermal mode and cooling method	cooling methods, from most preferred (for the unit to be used with a coldplate or heatsink it's necessary to consult with the producer)	1. Conductive - heatsink-coldplate. 2. Forced air heatsink cooler. 3. Convectonal heatsink cooling with vertical orientation of itself and vertical orientation of its ribs for free air flow from bottom to top.
Thermal resistance	case to ambient	6,5 °C/W
Humidity (non-condensing)		5-95 % rel. H
Insulation	in/case	1500 VAC
	in/out	3000 VAC
	out/case	500 VAC
	out/out	500 VDC
Isolating resistance @ 500 VDC		>20 MOhm
Thermal shock, mechanical shock & vibration		MIL-STD-810F
Safety standards		IEC/EN 60950-1
Typical MTBF	Pout = 0.7·Pout,max	600 000 hrs (Tcase = 25° C)
Weight (max)		75 g
Input characteristics ³		
Input voltage range (with power derating)	"270"	270 VDC nom., 155-375 VDC, surge 400 VDC 100ms
	"300"	300 VDC nom., 200-375 VDC, surge 400 VDC 100ms
	"150"	150 VDC nom., 82-200 VDC, surge 230 VDC 100ms
	"115"	115 VAC nom., 80-138 VAC, 113-195 VDC, surge 150 VAC 100ms
	"230"	230 VAC nom., 187-264 VAC, 263-372 VDC, no surge
Start-up input voltage	for "270" input	typ. 140 VDC
Output characteristics ³		
Output voltage adjustment	±10 % via ADJ output (see drawing)	
Output voltage regulation ²	input variance Uin,min to Uin,max	±0.5 % for load 10-100 %
	load variance 10 % to 100 %	±2 %
Ripple and noise (peak-to-peak)	20 MHz bandwidth	<1 % for load 10-100 %
Protection	over-current	auto-reset at 110-150 % of Iout,nom
	over-voltage	<130 % Uout
Capacitive load (max)	24 VDC, 50% Pout,nom	typ. 25 000 uF
Remote OFF (input)	connect ON to -IN or apply 0-0.5 VDC to ON	

1. See available filters on www.aeps-group.com.

2. -

3. All specifications are valid for normal climatic conditions, nominal output voltage and current, unless stated otherwise.

Minimal necessary connection scheme

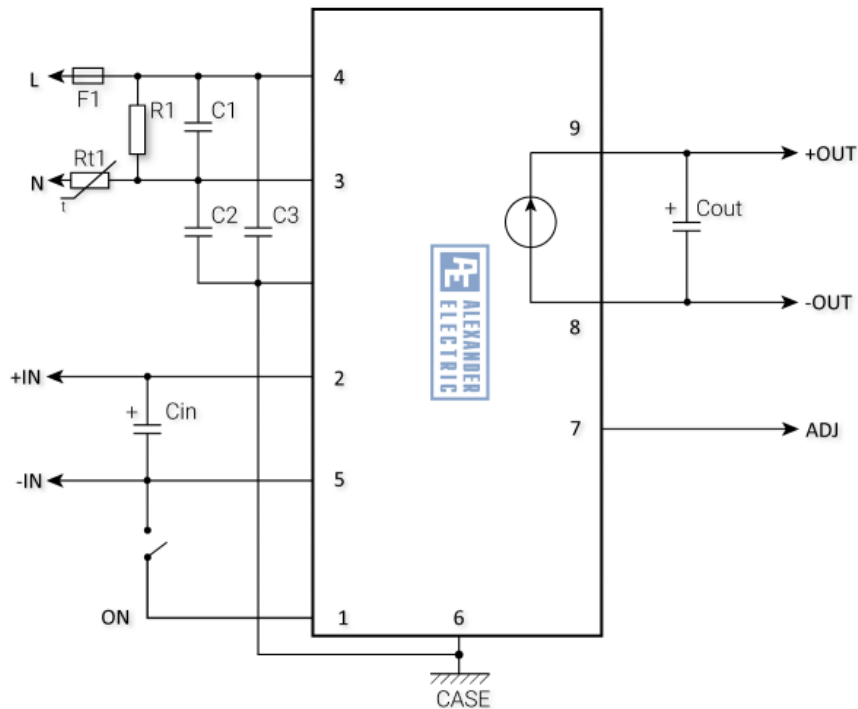

Recommended components for the "230" 50 Hz AC input, normal climatic conditions and 100% load

C1	2200 pF 275VAC, X2 class
C2, C3	2200 pF 250VAC, Y2 class
R1	470 kOhm 0.5W
Rt1	NTC 20 Ω
F1	6.3A 250V
Cin	220 μ F 400 V

Additional notes

1. To use with DC mains (i.e. "300") - connect the mains to +IN and -IN. Components Rt1, R1, C1, C2, C3 are not to be used in that case. Fuse F1 **must be placed at +IN** before Cin. Recommended Cin value for "300" DC mains is 27 μ F.
2. In case reverse polarity protection is required with DC mains, connect the mains to L and N. Components R1, C1, C2, C3 are not to be used.
3. Cout is not required for safe operation and its choice depends on the exact application requirements (i.e. for operation with impulse load). For recommended values please see point 5.6 in [Reference Technical Material for AC/DC units](#).

Power-temperature relationship

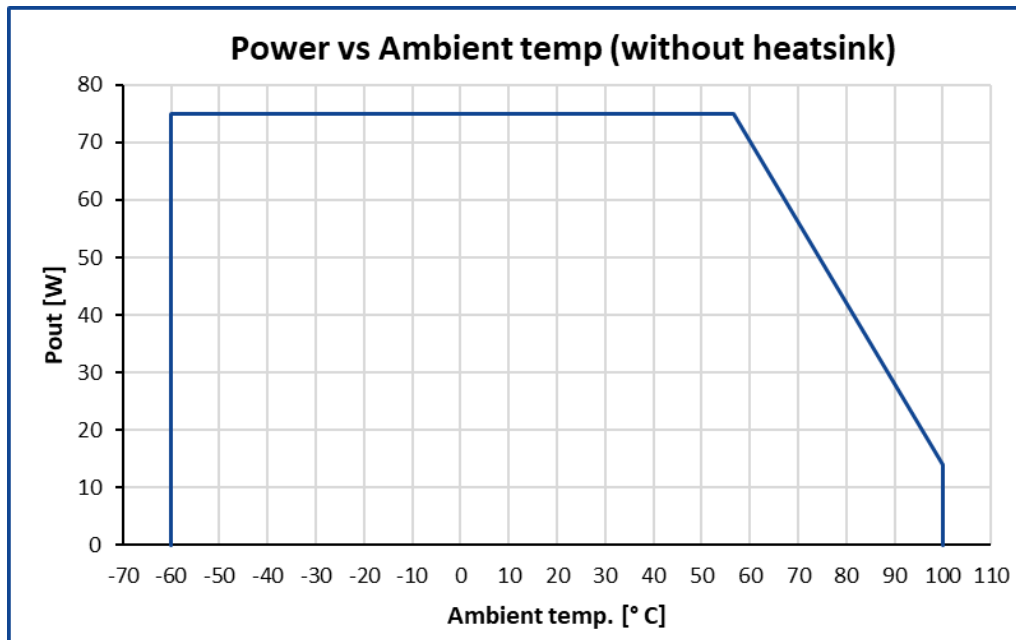
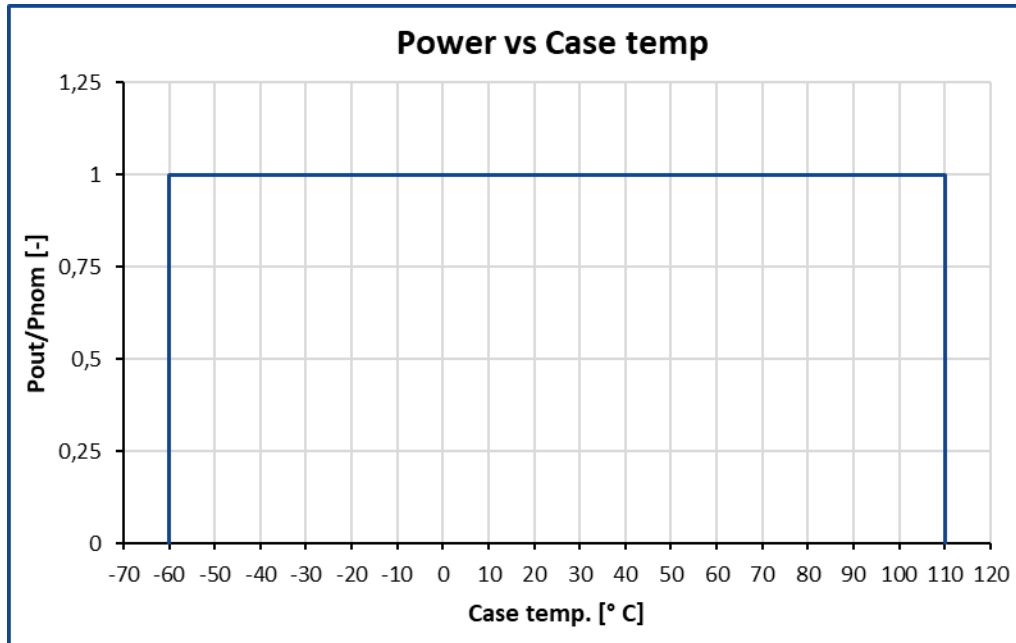

Power vs Ambient temp. graph is given for short-term use cases. To use the units without a heatsink it's mandatory to consult with the manufacturer.

Additional application information

1. Value of case temperature

The case temperature is measured at the middle of the long side of the case base. When using a thermocouple, it is necessary to attach the thermocouple conductors to the base surface at a distance of at least 20 mm from thermocouples head. **The thermocouple measuring end and its conductors must be covered with a layer of heat-conducting paste 2-3 mm thick to provide correct measurements.**

2. Possible cooling methods

- 1) Conductive cooling with aluminum (or copper) **heatsink or coldplate, with base at least 2 mm thick.**
- 2) Forced air.
- 3) Convectonal heatsink cooling with vertical orientation of itself and vertical orientation of its ribs for free air flow from bottom to top.

To use the units without a heatsink it's mandatory to consult with the manufacturer.

Most of the unit's dissipated heat (93-95 %) is concentrated **on the TOP SIDE of the unit (fully metal surface)** which must be attached to the heatsink-coldplate or ribbed heatsink surface. Requirements for the heatsink surface (preferably CNC milled) - flatness tolerance of the heatsink surface must be lower than 0.1 mm per 100 mm of length.

3. Unit heatsink fixation

If 4 mounting holes are available, then first one pair of diagonally located holes is connected with screws, then a second pair. First installation of the screws should be done without force. Then all the screws should be tightened with the recommended torque.

For quality contact between the unit and a heatsink - it's necessary to use thermal conductive paste with thickness less than 0.1 mm, with thermal conductivity **greater than 2 W/K.m**. The paste must be applied with mesh stencil in a pattern of squares (i.e. 2x2 mm to 4x4 mm squares mm with 0.5-1 mm spacing between the squares). This allows paste to be evenly spread in a thin layer and excess air to escape when tightening screws during unit mounting.

4. Short-term unit operation

If it's necessary to shortly turn on the unit for 3-5 minutes (for example for input-control testing), an aluminum (copper) coldplate must be used as a heatsink. Its width and length must be not less than of the unit itself, with thickness at least 10 mm. The unit must be placed on coldplate through a thin (0.15-0.3 mm) silicone-based heat-conducting sheet.

5. Thermal protection tripping

When internal unit's thermal protection is tripped (typ. +110 °C) the unit is turned off (until automatic restart). **Such state should lead to measures of forced heatsink cooling, for example via fans turn-on.** Time before automatic restart of the unit after thermal protection tripping can last from several seconds up to several minutes depending on thermal inertia of the heatsink.

6. Operation with shorted outputs

The units have a short-circuit output protection. **The protection is for emergency only, not for long-term operation. It's prohibited to use the units with shorted outputs (the units have the special detectors inside).**

If you have any questions, please contact us directly at aepe@aepe-group.cz.

Dimensions - one channel

1	2	3	4	5	6	7	8	9
ON	+IN	N	L	-IN	CASE	ADJ	-OUT	+OUT

Dimensions in millimeters, 4 installation holes, PCB mounting only.

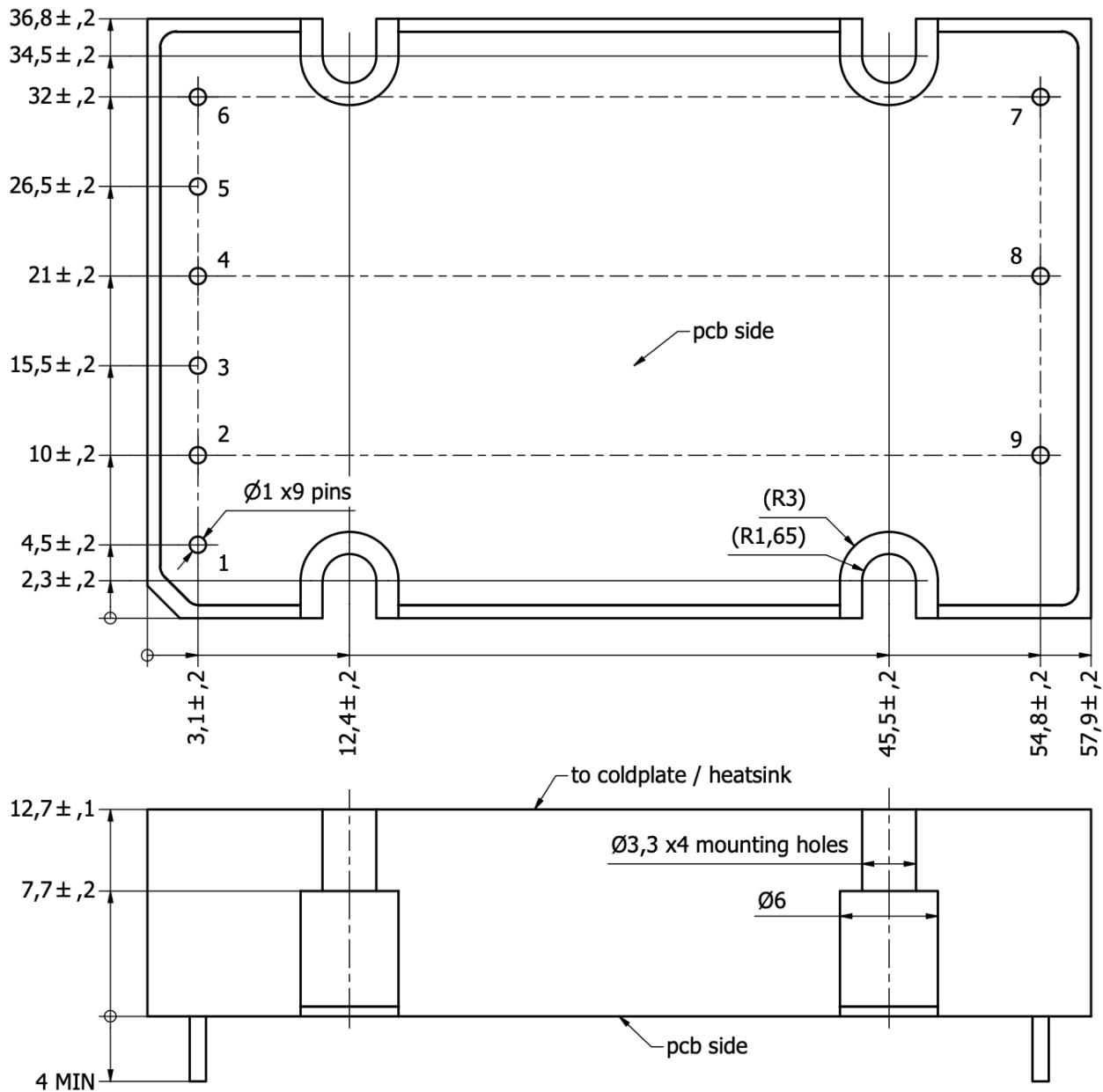

Additional information

After ordering the product - the customer is fully responsible for applying the product in strict compliance with mentioned rules and principles of use in the product datasheet and reference technical material (RTM) which is downloadable at www.aeps-group.com.

Please, note that all information in this material is for reference only. Further detailed information (including: additional requirements, manuals and circuit schemes, etc.) is found at www.aeps-group.com or provided via an email request at aeps@aeps-group.cz. All pictures shown are for illustration purpose only, actual product appearance may vary, incl. inner components choice and placement and connectors placement.

According to company's policy in view of constant improvements of the production design the manufacturer reserves the right to change the contents of specifications and promotional materials without prior notice! Make sure you are using the latest documentation downloadable at www.aeps-group.com.

© «AEPS-GROUP». All rights reserved.