

Features

- Up to 20 W output power, 54 W/in³
- Extreme case operating temp. range for request up to -60...+130 °C
- Efficiency up to 89 %
- 30x20x10 (mm) aluminium case (dim. without flanges)
- Input ranges:
"27W" - (15-50 VDC) - standard
- Output voltage trimming
- Remote on/off
- One or two galvanically isolated outputs
- Ability to achieve increased output voltage via serial connection of outputs



Description

TESND20-F1 are the series of isolated DC/DC converters meant to work under both heavy electrical and environmental conditions. Output power is **up to 20 Watts**, power density is up to **54 W/in³**, with standard of **-40° to +110° C**. The units feature a system of over-current protection and over-voltage protection. Standard functions include remote on/off and output voltage trimming. Its versatility allows you to implement the converter in a vast number of industrial applications, supplying capacitive, constant-power and impulse load. Application fields: low-high altitude, land transport, supercomputers, mining, equipment in high and low temperature regions, digital signage equipment, APAR radars and others - where there are needed low-profile and high efficiency.

When ordering nominal power may be chosen from 5, 6, 8, 10, 15 and 20 W

One channel 20 W model*	Input voltage range**	Power max.	Output voltage nom.***	Output current max.	Efficiency typ.
TESND20-27WS03-F1-xC	15-50 VDC (80 VDC 1s transient)	12 W	03 V	4.00 A	83 %
TESND20-27WS05-F1-xC		20 W	05 V	4.00 A	85 %
TESND20-27WS12-F1-xC		20 W	12 V	1.67 A	87 %
TESND20-27WS15-F1-xC		20 W	15 V	1.33 A	87 %
TESND20-27WS24-F1-xC		20 W	24 V	0.83 A	87 %
TESND20-27WS27-F1-xC		20 W	27 V	0.74 A	87 %
TESND20-27WS36-F1-xC		20 W	36 V	0.56 A	88 %
TESND20-27WS48-F1-xC		20 W	48 V	0.42 A	88 %
TESND20-27WS60-F1-xC		20 W	60 V	0.33 A	89 %

* Index of temperature range (instead of X): -40...+110 °C (S), -60...+110 °C (M), -40...+130 °C (P), -60...+130 °C (E);

* Index of case height: "C" - standard height;

** Units with different input voltage ranges, may be provided on request (please check the [selection guide](#)).

*** Models with custom output voltage may be provided on request.

When ordering nominal power may be chosen from 5, 6, 8, 10, 15 and 20 W

Dual channel 20 W model*	Input voltage range**	Power max.	Output voltage nom.***	Output current max. per channel	Efficiency typ.
TESND20-27WD0303-F1-xC	15-50 VDC (80 VDC 1s transient)	12 W	2 x 03 V	2.00 A	82 %
TESND20-27WD0505-F1-xC		20 W	2 x 05 V	2.00 A	84 %
TESND20-27WD1212-F1-xC		20 W	2 x 12 V	0.83 A	86 %
TESND20-27WD1515-F1-xC		20 W	2 x 15 V	0.67 A	86 %
TESND20-27WD2424-F1-xC		20 W	2 x 24 V	0.42 A	86 %
TESND20-27WD2727-F1-xC		20 W	2 x 27 V	0.37 A	86 %
TESND20-27WD3636-F1-xC		20 W	2 x 36 V	0.28 A	87 %
TESND20-27WD4848-F1-xC		20 W	2 x 48 V	0.21 A	87 %
TESND20-27WD6060-F1-xC		20 W	2 x 60 V	0.17 A	88 %

* Index of temperature range (instead of X): -40...+110 °C (S), -60...+110 °C (M), -40...+130 °C (P), -60...+130 °C (E);

* Index of case height: standard "C";

** Units with different input voltage ranges, may be provided on request (please check the [selection guide](#)).

*** Models with custom output voltage may be provided on request.

General specifications

Switching frequency		400 kHz typ. (PWM modulation)
Temperature ranges	operating case temp.	-40 °C to +110 °C (Standard "S" range)
	storage temp.	-60 °C to +130 °C
Over-temperature protection		+115 °C typ.
Thermal mode and cooling method		conductive via heatsink or natural convection
Thermal resistance, case-ambient	natural convection	18 K/W typ.
Humidity (non-condensing)		5-95 % rel. H
Insulation	input/case, input/output	1500 VDC
	output/case	1000 VDC
	output/output	500 VDC
Isolating resistance @ 500 VDC		>20 MOhm
Thermal shock, mechanical shock & vibration		MIL-STD-810F
Safety standards		IEC/EN 60950-1
Typical MTBF	$P_{out} = 0.7 \cdot P_{out.max}$	190 000 hrs (T _{case} = 50 °C)
Weight (max)		17 g

Input specifications

Input voltage range	range "27W"	15-50 VDC (80 VDC 1s transient)
Start-up input voltage		12-15 VDC
EMC standard compliance*	CE MIL-STD-461F, with typical connection scheme, use JETDF2.5 to improve filtration	

Output specifications

Output voltage adjustment	in range ± 5 %, via ADJ output (see drawing)	
Output voltage regulation**	input variance U _{in,min} to U _{in,max}	± 0.5 %
	load var. 10 % to 100 %	± 2 %

Ripple and noise (peak-to-peak)	20 MHz bandwidth	<2 %
Protection	over-load	auto-reset at 110-150 % of Iout,nom
	over-voltage	<130 % Uout
Capacitive load (max)	24 VDC output (50% Pout) - typ. 5 200 μ F	
Minimum load	<i>not required</i>	
Remote Off	connect ON to -IN or apply 0-0.5 VDC to ON	

* See product page for DC/DC filters at www.aeps-group.com.

** When varying load in the main stabilized channel from 10 % to 100 %, secondary output voltage regulation may reach ± 13 %
Please contact the tech. team at aeps@aeps-group.cz for more information.

All specifications are valid for normal climatic conditions, nominal output voltage and current, unless otherwise stated.

Typical connection scheme (minimum required)

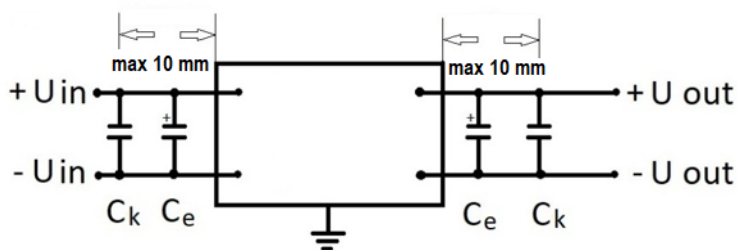

The design of the units allows their use only when mounted on a PCB. It's necessary to use certain type components. In the figure: Ck – ceramic capacitors of a certain operating voltage and of several μ F capacity; Ce – electrolytic capacitors of a certain operating voltage and of polymer, aluminum or tantalum type of tens to

hundreds μ F capacity. For component values – please see point 5.5 in [Reference Technical Material for DC/DC units](#).

Max output power based on case temperature

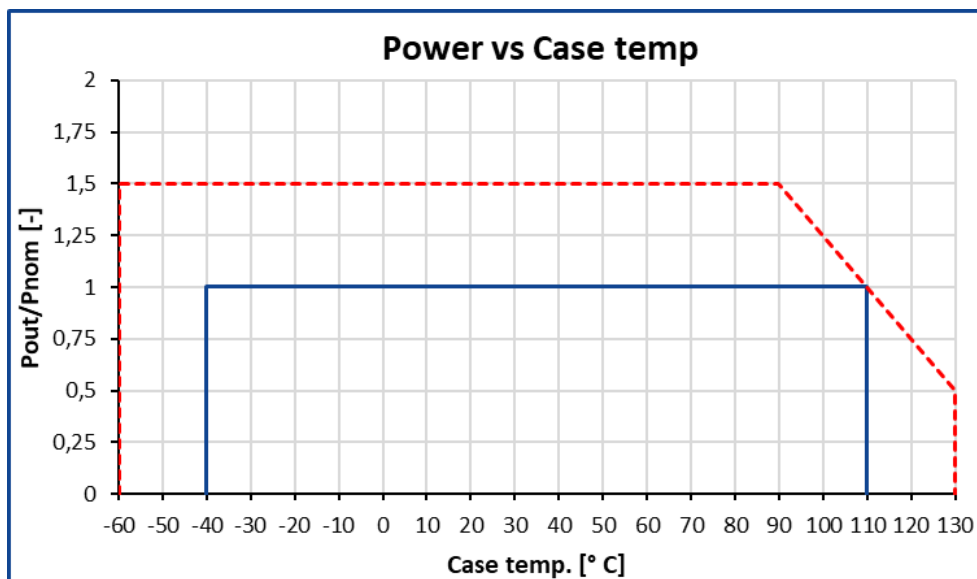

— Standard maximum power output based on case temperature.

- - - Possible range of output power for customized product.

Before operation, the product label on converter top side has to be removed.

If chosen cooling method is conduction, the unit must be operated on a heatsink with thermal conductive paste applied between the unit surface and a heatsink for quality contact (with thickness less than 100 μ m, with thermal conductivity greater than 2 W/K.m). Mesh stencil should be used to apply paste in a pattern of 2x2 mm to 4x4 mm squares mm with 0.5-1 mm spacing between the squares. This allows paste to be evenly spread in a thin layer and excess air to escape when tightening screws during unit mounting.

Note:

The units have a short-circuit output protection, which is for emergency only, not for long-term operation. It's prohibited to use the units with reversed input voltage polarity or turn on the units with short-circuited outputs (the units have the special detectors inside).

Max output power based on ambient temperature

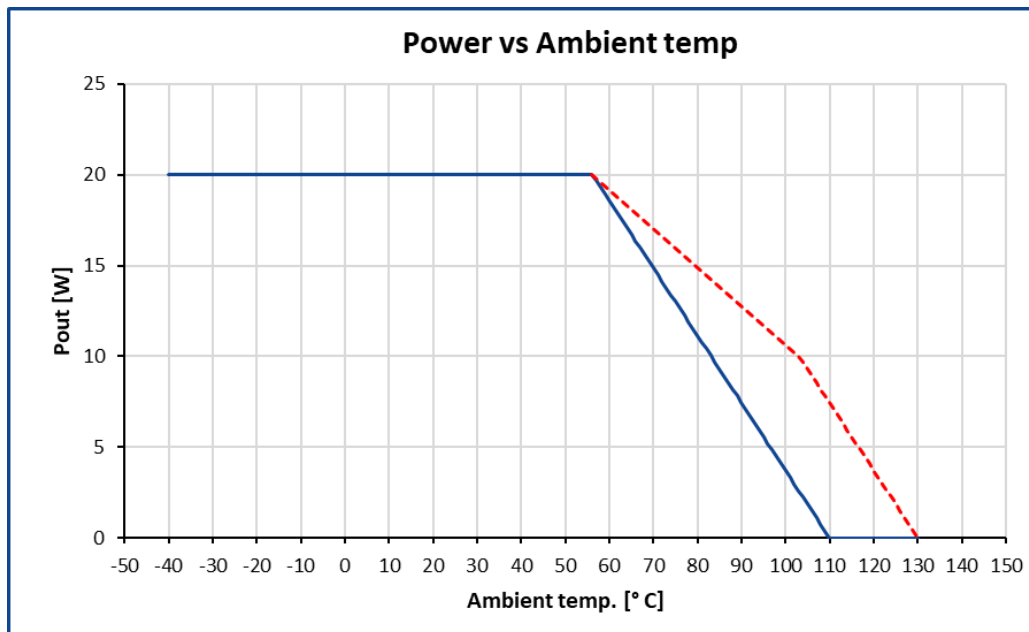

— for temperature range up to +110 °C

- - - for temperature range up to +130 °C

The graph is constructed for a 20 W model with 87% efficiency.

Before operation, the product label on converter top side has to be removed.

When using the unit without heatsink it's assumed that the units are located on a vertically-oriented PCB that does not have any other significant heat sources other than the units themselves. It is allowed to use the units on a horizontally-oriented PCB when placing the units on the upper side. In any case, it is necessary to provide unrestricted air convection around the units.

Note:

The units have a short-circuit output protection, which is for emergency only, not for long-term operation. It's prohibited to use the units with reversed input voltage polarity or turn on the units with short-circuited outputs (the units have the special detectors inside).

If you have any questions please contact us directly at aeps@aeps-group.cz.

MTBF based on case temperature

When using the unit, a customer must in one way or another monitor maximal heatsink temperature. Maximal heatsink temperature near the center point of the longer unit's side (considered as unit case temperature) must correspond to the expected unit's MTBF. Approximate MTBF function shown on the graph lower, where $MTBF / MTBF_{50}$ is unit's MTBF value at chosen unit's case operating temperature relative to value at 50°C unit's case temperature.

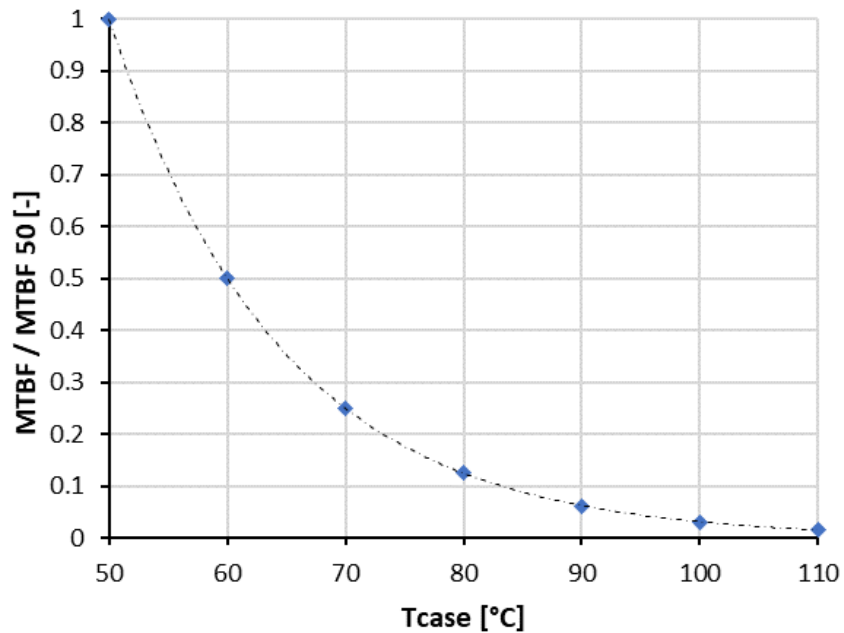

Dimensions

Pin #	1,2	3	4	5	6	7	8	9,10	11
Single ch.	-IN	ON	n.u.	n.u.	+OUT	ADJ	-OUT	+IN	CASE
Dual ch.	-IN	ON	+OUT2	-OUT2	+OUT1	n.u.	-OUT1	+IN	CASE

Dimensions in millimeters, 2 installation holes, PCB mounting only

Single channel

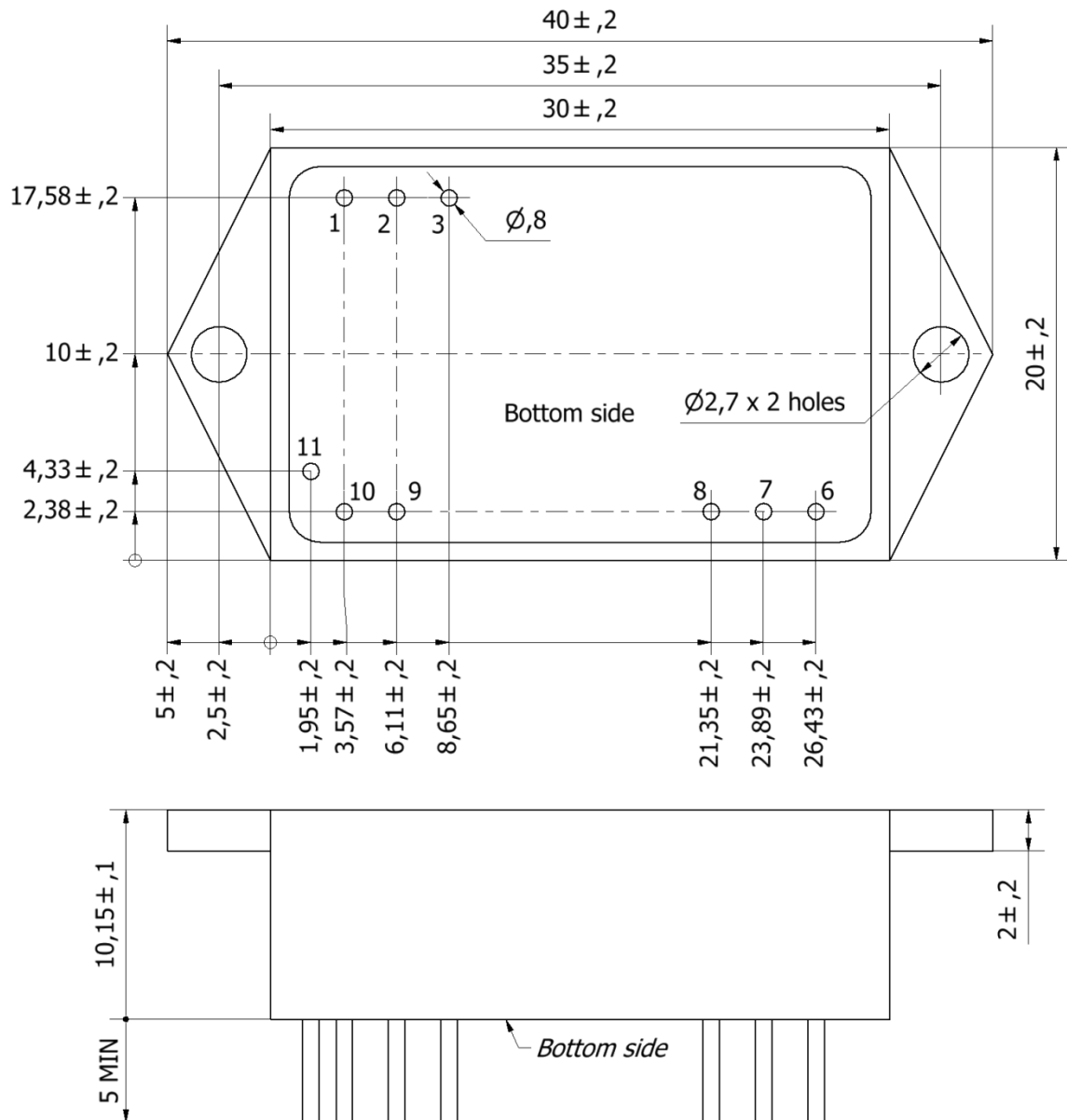

Dual channel

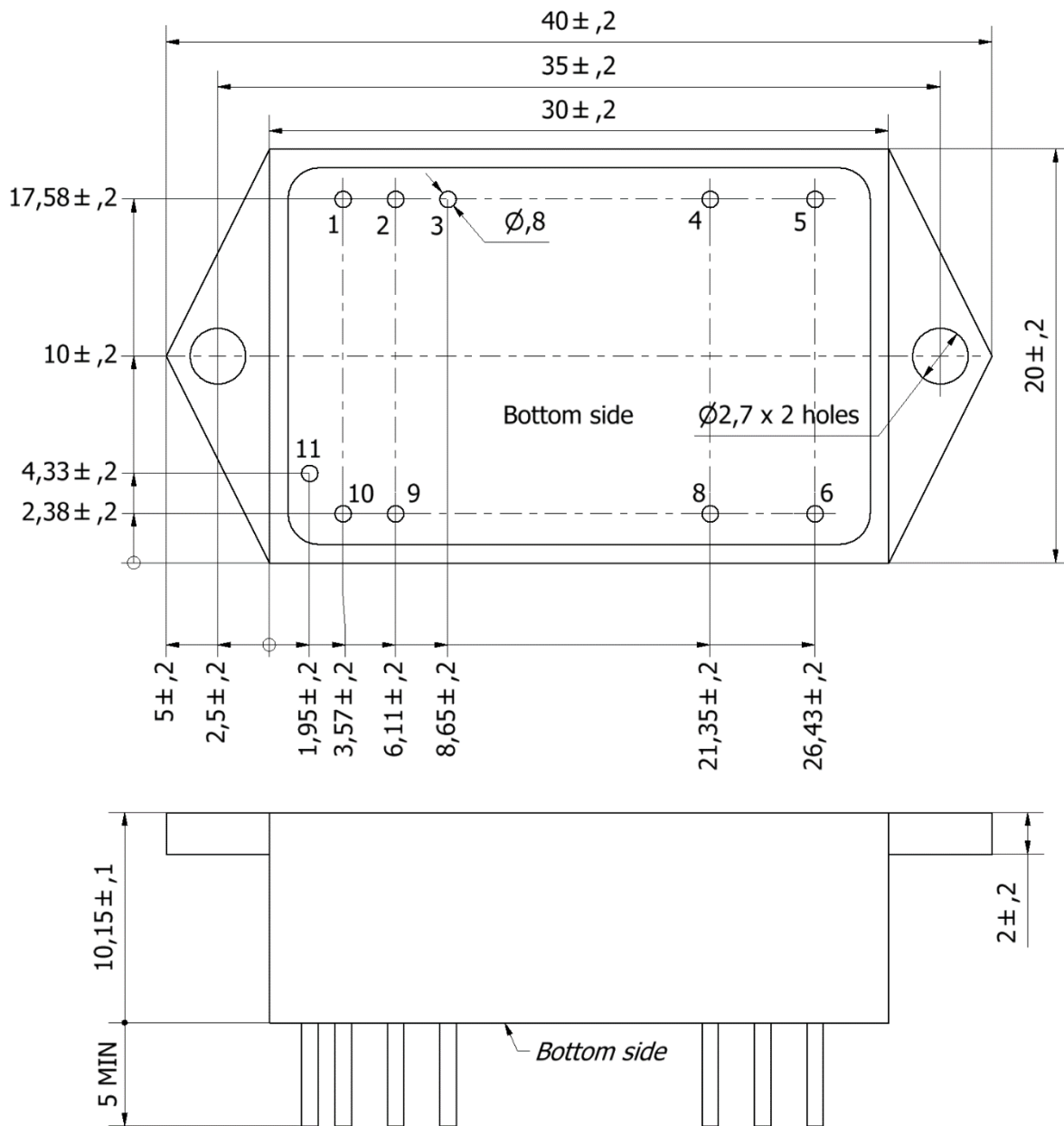

Additional information

After ordering the product - the customer is fully responsible for applying the product in strict compliance with mentioned rules and principles of use in the product datasheet and reference technical material (RTM) which is downloadable at www.aeps-group.com.

Please, note that all information in this material is for reference only. Further detailed information (including: additional requirements, manuals and circuit schemes) is found at www.aeps-group.com or provided via an email request at aeps@aeps-group.cz. All pictures shown are for illustration purpose only, actual product appearance may vary, incl. inner components choice and placement and connectors placement.

According to company's policy in view of constant improvements of the production design the manufacturer reserves the right to change the contents of specifications and promotional materials without prior notice! Make sure you are using the latest documentation downloadable at www.aeps-group.com.

© «AEPS-GROUP». All rights reserved.