

Features

- Up to 200 W output power, 32 W/in³
- Series for project "constructor", ultra-low profile to be used with external components and operate at AC and/or DC input voltage ranges
- TESH series contain single input to be used with high voltage DC input range
- Extreme case operating temp. range for request up to -60° ... +110° C
- Efficiency up to 93 %
- 73x53x13 (mm) metal case with flanges (size without flanges)
- Input standard:
"230" - 176-264 VAC or 175-372 VDC.
Also possible for TESAV: "115"
Possible for TESH: "115", "150W", "230"
- Output voltage adjustment
- Remote on/off
- External feedback



Description

TESAV100-F5 is the series of isolated **ultra-low-profile** dual input AC-DC/DC power supplies meant to work under both heavy electrical and environmental conditions. **Units are meant to be implemented in "constructor" project, to be used with additional external components and to be operated at AC and/or DC input voltage ranges.** Output power is **up to 100 Watts**, power density is up to **32 W/in³**, with standard of **-40° to +110° C**. The units feature a system of over-current protection and over-voltage protection. Standard functions include remote on/off and output voltage trimming. Its versatility allows you to implement the converter in a vast number of industrial applications, supplying capacitive, constant-power and impulse load. Application fields: low-high altitude, land transport, supercomputers, mining, equipment in high and low temperature regions, digital signage equipment, APAR radars and others - where there are needed low-profile and high efficiency.

TESAV / TESH, nominal power may be chosen from 50 and 100 W

One channel 100 W model*	Input voltage range**	Power max.	Output voltage nom.***	Output current max.	Efficiency typ.
TESAV 100 - 230 S05-F5-xU	for AC input: 176-264 VAC for DC input: 175-372 VDC	100 W	05 V	20.0 A	88 %
TESAV 100 - 230 S12-F5-xU		100 W	12 V	8.3 A	90 %
TESAV 100 - 230 S15-F5-xU		100 W	15 V	6.7 A	91 %
TESAV 100 - 230 S24-F5-xU		100 W	24 V	4.2 A	92 %
TESAV 100 - 230 S27-F5-xU		100 W	27 V	3.7 A	92 %
TESAV 100 - 230 S36-F5-xU		100 W	36 V	2.8 A	92 %
TESAV 100 - 230 S48-F5-xU		100 W	48 V	2.1 A	93 %
TESAV 100 - 230 S60-F5-xU		100 W	60 V	1.7 A	93 %

* Index of temperature range (instead of X): -40...+110° C (S), -60...+110° C (M)

* Replace TESAV for TESH to order TESH variant; 230 signifies standard input range "230"

** Units with different input voltage ranges, may be provided on request (please check the [selection guide](#)).

*** Models with custom output voltage may be provided on request.

TESAV / TESH, nominal power may be chosen from 50 and 100 W

Dual channel 100 W model*	Input voltage range**	Power max.	Output voltage nom.***	Output current max. per channel	Efficiency typ.	
TESAV 100 - 230 D0505-F5-xU	for AC input: 176-264 VAC	100 W	2 x 05 V	10.0 A	87 %	
TESAV 100 - 230 D1212-F5-xU		100 W	2 x 12 V	4.2 A	89 %	
TESAV 100 - 230 D1515-F5-xU		100 W	2 x 15 V	3.3 A	90 %	
TESAV 100 - 230 D2424-F5-xU		100 W	2 x 24 V	2.1 A	91 %	
TESAV 100 - 230 D2727-F5-xU		for DC input: 175-372 VDC	100 W	2 x 27 V	1.9 A	91 %
TESAV 100 - 230 D3636-F5-xU			100 W	2 x 36 V	1.4 A	91 %
TESAV 100 - 230 D4848-F5-xU			100 W	2 x 48 V	1.0 A	92 %
TESAV 100 - 230 D6060-F5-xU			100 W	2 x 60 V	0.8 A	92 %

* Index of temperature range (instead of X): -40...+110° C (S), -60...+110° C (M)

* Replace TESAV for TESH to order TESH variant; 230 signifies standard input range "230"

** Units with different input voltage ranges, may be provided on request (please check the [selection guide](#)).

*** Models with custom output voltage may be provided on request.

General specifications

Switching frequency		300 kHz typ. (PWM modulation)
Temperature ranges	operating case temp.	-40° C to +110° C (Standard "S" range)
	storage temp.	-60° C to +130° C
Over-temperature protection		+115° C typ.
Thermal mode and cooling method		conductive via heatsink or natural convection
Thermal resistance, case-ambient	natural convection	5 K/W typ.
Humidity (non-condensing)		5-95 % rel. H
Insulation	input/case	1500 VAC
	input/output	3000 VAC
	output/case	500 VAC
	output/output	500 VDC
Isolating resistance @ 500 VDC		>20 MOhm
Thermal shock, mechanical shock & vibration		MIL-STD-810F
Safety standards		IEC/EN 60950-1
Typical MTBF	Pout = 0.7·Pout,max	100 000 hrs (Tcase = 50° C)
Weight (max)		135 g

Input specifications

Input voltage frequency	50 Hz (up to 400 Hz on request) AC or DC	
AC input ranges for TESAV, using inputs L, N	"230" (176-264 VAC), "115" (80-140 VAC)	
DC input ranges for TESAV, using inputs +IN, -IN	"230" (175-372 VDC), "115" (82-198 VDC)	
DC input ranges for TESH, using inputs +IN, -IN	"115" (82-198 VDC), "150W" (110-375 VDC), "230" (175-372 VDC)	
EMC standard compliance*	with additional filter CE MIL-STD-461F or CE EN 55022 (class A/B)	
Power Factor		n.a.

Output specifications

Output voltage adjustment	in range $\pm 5\%$, via ADJ output (see drawing)	
Output voltage regulation**	input variance $U_{in,min}$ to $U_{in,max}$	$\pm 0.5\%$ for load 10-100 %
	load variance 10 % to 100 %	$\pm 2\%$
Ripple and noise (peak-to-peak)	20 MHz bandwidth	$< 2\%$ for load 10-100 %
Protection	over-current	auto-reset at 110-150 % of $I_{out,nom}$
	over-voltage	$< 130\%$ U_{out}
Capacitive load (max)	13 000 μF ($U_{out} = 24$ VDC, 50% $P_{out,nom}$)	
Remote Off	connect ON to -IN or apply 0-0.5 VDC to ON	

* See product page for filters at www.aeps-group.com.

** When varying load in the main stabilized channel from 10 % to 100 %, secondary output voltage regulation may reach $\pm 13\%$
Please contact the tech. team at aeps@aeps-group.cz for more information.

All specifications are valid for normal climatic conditions, nominal output voltage and current, unless otherwise stated.

Typical connection scheme (minimum required)

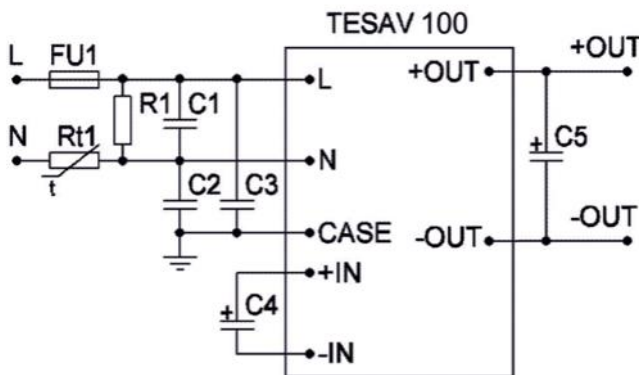

For input "230", AC 50 Hz or DC

for TESAV	
C1	0.15 μF 275VAC, X2 class
C2, C3	2200 pF 250VAC, Y2 class
R1	470kOhm 0.5W
Rt1	NTC 15 Ω 3A
FU1	6.3A 250V
for TESAV / TESH	
C4	120 μF 400 V for normal climatic conditions and 100 % load
C5	Tantalum, Low ESR

The design of the units allows their use only when mounted on a PCB. When using the units with typical connection scheme it's necessary to use certain type components. For C5 values – please see point 5.6 in [Reference Technical Material for AC/DC units](#).

Max output power based on case temperature

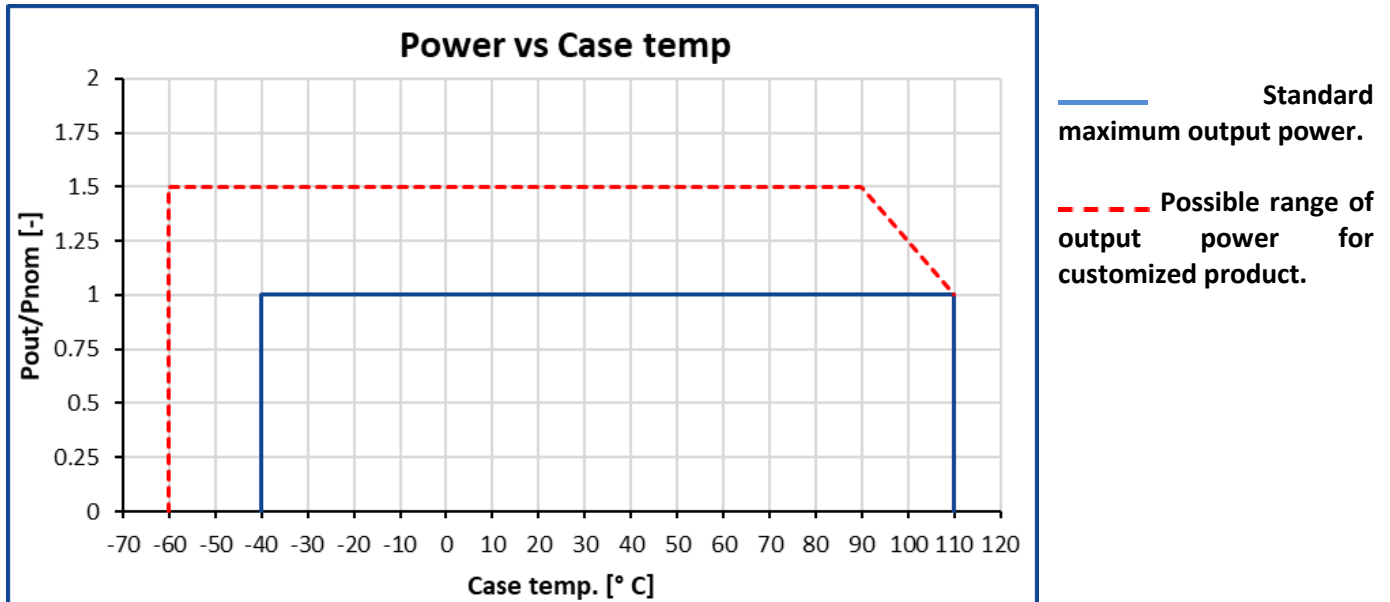

Before operation, the product label on converter top side has to be removed.

If chosen cooling method is conduction, the unit must be operated on a heatsink with thermal conductive paste applied between the unit surface and a heatsink for quality contact (with thickness less than 100 μm , with thermal conductivity greater than 2 W/K.m). Mesh stencil should be used to apply paste in a pattern of 2x2 mm to 4x4 mm squares mm with 0.5-1 mm spacing between the squares. This allows paste to be evenly spread in a thin layer and excess air to escape when tightening screws during unit mounting.

Note:

The units have a short-circuit output protection, which is for emergency only, not for long-term operation. It's prohibited to use the units with reversed input voltage polarity or turn on the units with short-circuited outputs (the units have the special detectors inside).

Max output power based on ambient temperature

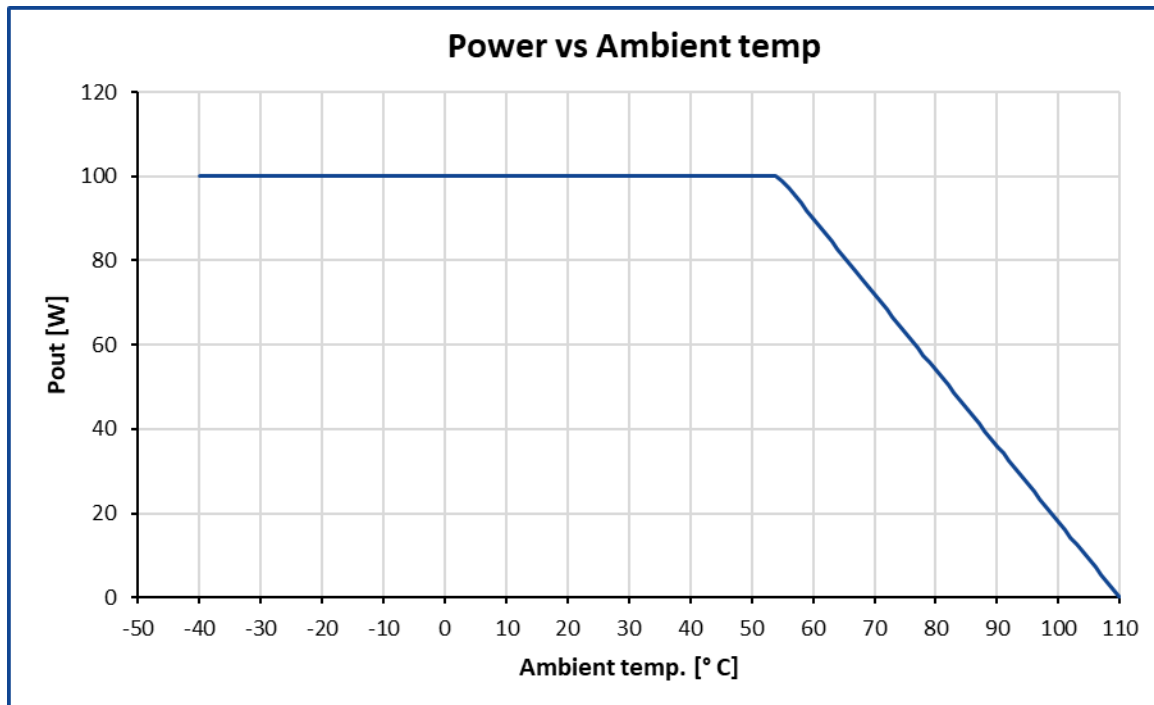

The graph is constructed for a 100 W model with 90 % efficiency.

Before operation, the product label on converter top side has to be removed.

When using the unit without heatsink it's assumed that the units are located on a vertically-oriented PCB that does not have any other significant heat sources other than the units themselves. It is allowed to use the units on a horizontally-oriented PCB when placing the units on the upper side. In any case, it is necessary to provide unrestricted air convection around the units.

Note:

The units have a short-circuit output protection, which is for emergency only, not for long-term operation. It's prohibited to use the units with reversed input voltage polarity or turn on the units with short-circuited outputs (the units have the special detectors inside).

If you have any questions please contact us directly at aeps@aeps-group.cz.

MTBF based on case temperature

When using the unit, a customer must in one way or another monitor maximal heatsink temperature. Maximal heatsink temperature near the center point of the longer unit's side (considered as unit case temperature) must correspond to the expected unit's MTBF. Approximate MTBF function shown on the graph lower, where MTBF / MTBF 50 is unit's MTBF value at chosen unit's case operating temperature relative to value at 50°C unit's case temperature.

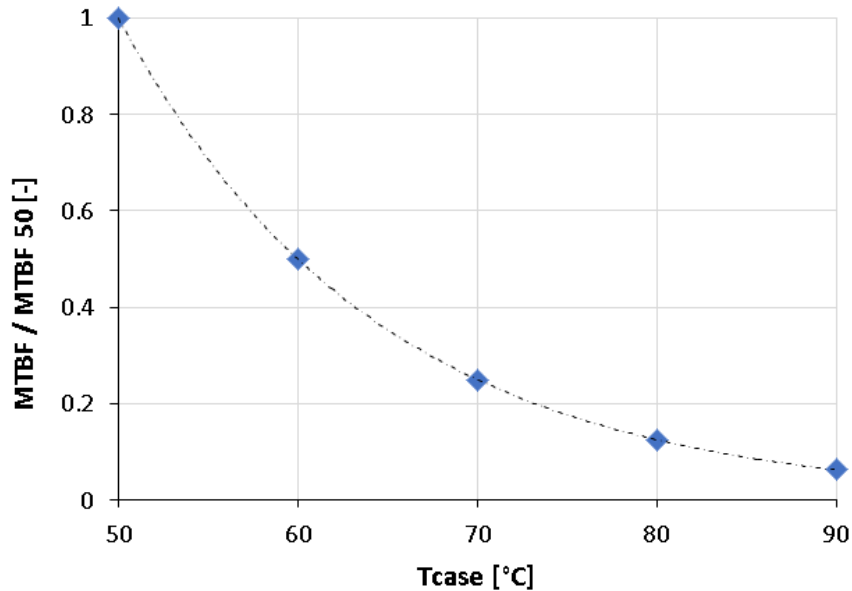

Thermal protection tripping

When internal unit's thermal protection is tripped (typ. +110°C ... +120°C) the unit is turned off (until automatic restart). Such state should lead to measures of forced heatsink cooling, for example via fans turn-on. In case of long-term unit operation in such conditions (particularly in case with close-to-zero loads) there is a possibility of failure due to frequent turning off and on at maximal unit's heatsink temperature. Time before automatic restart of the unit after thermal protection tripping can last from several seconds up to several minutes depending on thermal inertia of the heatsink.

If you have any questions please contact us directly at aeps@aeps-group.cz.

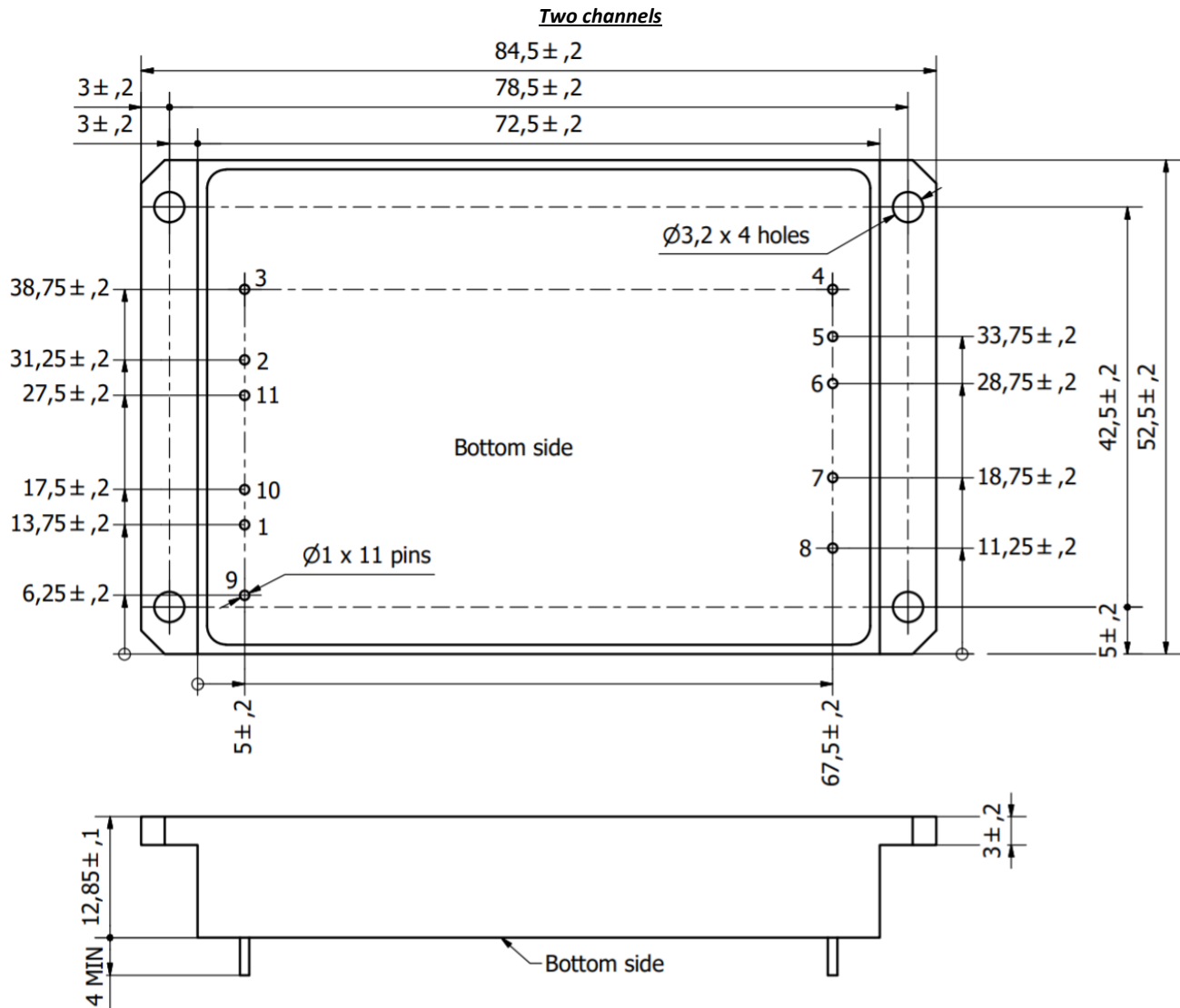

Additional information

After ordering the product - the customer is fully responsible for applying the product in strict compliance with mentioned rules and principles of use in the product datasheet and reference technical material (RTM) which is downloadable at www.aeps-group.com.

Please, note that all information in this material is for reference only. Further detailed information (including: additional requirements, manuals and circuit schemes) is found at www.aeps-group.com or provided via an email request at aeps@aeps-group.cz. All pictures shown are for illustration purpose only, actual product appearance may vary, incl. inner components choice and placement and connectors placement.

According to company's policy in view of constant improvements of the production design the manufacturer reserves the right to change the contents of specifications and promotional materials without prior notice! Make sure you are using the latest documentation downloadable at www.aeps-group.com.

© «AEPS-GROUP». All rights reserved.