

Features

- For AC networks
- Nominal current up to 1 A
- Case operating temp. range up to -50...+85 °C
- 58x40x10 (mm) metal case with mounting flanges (dimensions are without flanges)
- Variants input:
230W - (100-242 VAC) - standard, other:
115, 230
- Minimum insertion 55 dB for 1-10 MHz
- Overvoltage protection



Description

JETAF1 - protection and filtration modules (filters) for harsh environment are designed to operate in AC networks and to protect analog and digital equipment from surges and to filter noises in the input and output circuits of the modules and power supply units. Filters are suitable for all types of applications and feature wide temperature range that allows their application in equipment designated for different climatic conditions, including high humidity. High reliability is guaranteed by using the newest component base. Amorphous nanocrystal line cores in common mode chokes provide reliable noise filtering and temperature stability. Maximum effect is achieved when combining the application of these filters with AC/DC power supplies produced by AEPs-group.

Models

Model*	Input voltage range	Voltage suppression @ 1mA	Rated current	Current surge, max. 8/20 μs
JETAF1-230W-xy	100-264 VAC, 50 Hz	430 VDC	1.00 A	1.2 kA
JETAF1-230-xy	182-264 VAC, 50 Hz	430 VDC		
JETAF1-115-xy	81-138 VAC, 50 Hz	240 VDC		

* Index of case type (instead of X): with flanges (U), without flanges (C);

* Index of temperature range (instead of Y): -40...+85° C (N), -50...+85° C (P)

General specifications		
Temperature ranges	operating case temp.	-40° C to +85° C (Standard "N" range)
	storage temp.	-60° C to +85° C
Thermal mode and cooling method		conductive via heatsink or natural convection
Thermal resistance	case-environment	7.8 K/W typ.
Humidity (non-condensing)		5-95 % rel. H
Insulation	input/case, output/case	1500 VAC
Isolating resistance @ 500 VDC		>20 MOhm
Thermal shock, mechanical shock & vibration		MIL-STD-810F
Safety standards		IEC/EN 60950-1
Typical MTBF	Tcase = 25° C	650 000 hrs
Weight (max)		65 g
Output specifications		
Insertion loss in frequency range	0.15-0.3 Mhz	≥20 dB
	0.3-1 Mhz	≥35 dB
	1-10 Mhz	≥55 dB
	10-30 Mhz	≥50 dB
Filter voltage drop		≤2,3 VAC

Please contact the tech. team at aeps@aeps-group.cz for more information.

All specifications are valid for normal climatic conditions, nominal output voltage and current, unless otherwise stated.

Dimensions

1	2	3	4	5
IN N	IN L	CASE	OUT N	OUT L

Dimensions in millimeters

with flanges (U version)

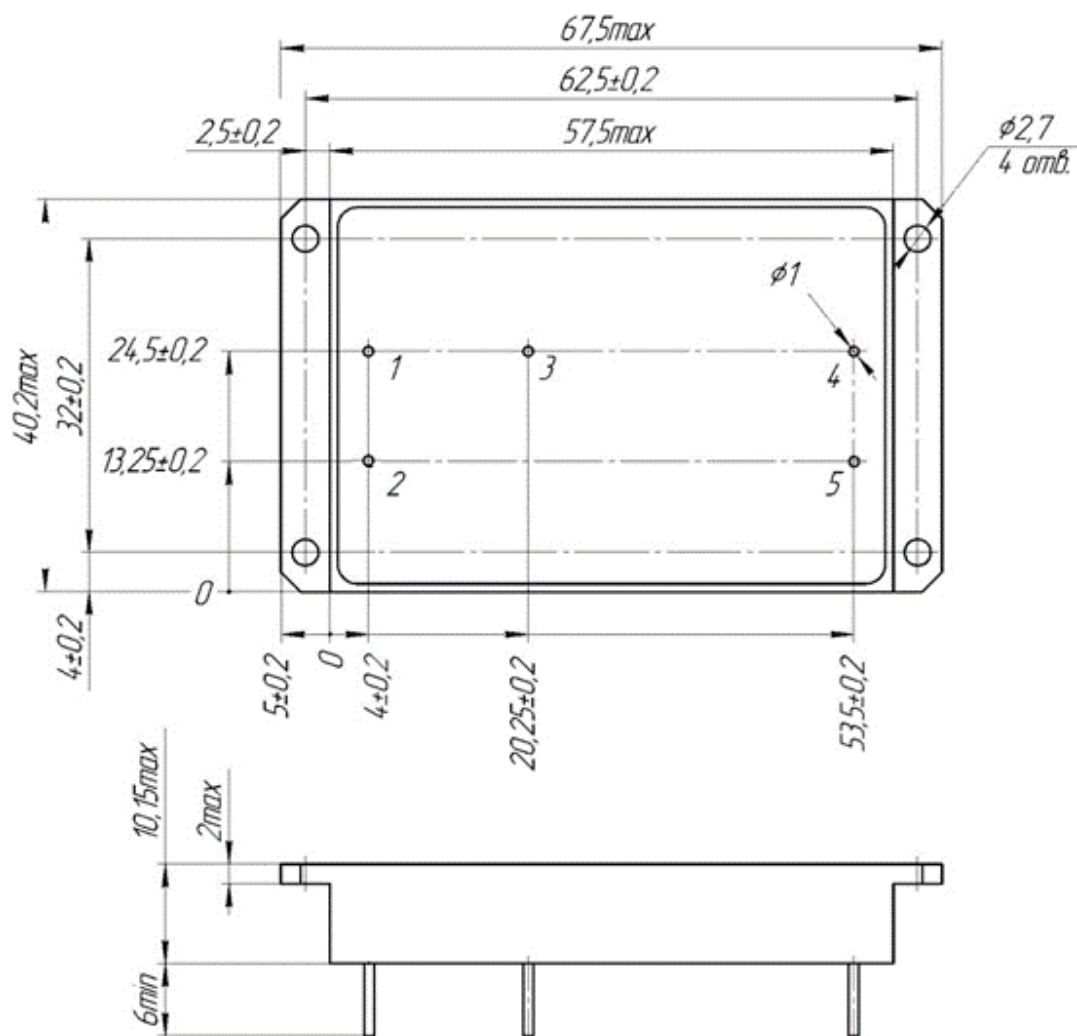

without flanges (C version)

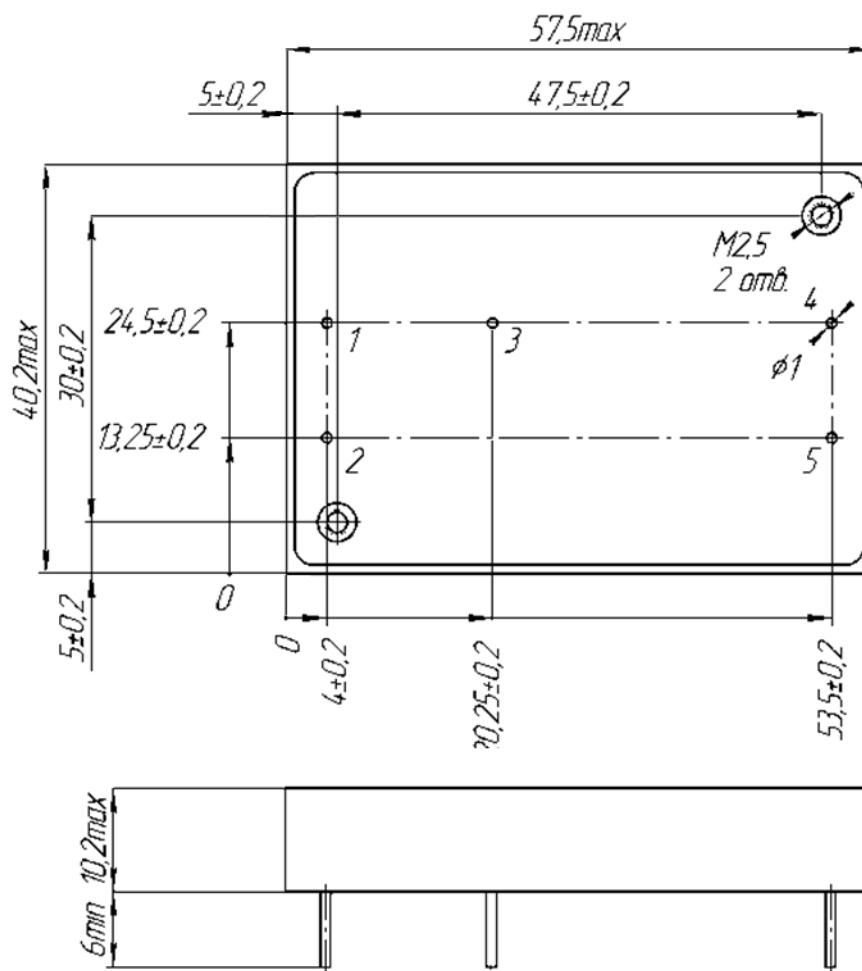

Additional information

Please, note that all information in this material is for reference only. Further detailed information (including: additional requirements, manuals and circuit schemes) is found at www.aeps-group.com or provided via an email request at aeps@aeps-group.cz. All pictures shown are for illustration purpose only, actual product appearance may vary, incl. inner components choice and placement and connectors placement.

According to company's policy in view of constant improvements of the production design the manufacturer reserves the right to change the contents of specifications and promotional materials without prior notice! Make sure you are using the latest documentation downloadable at www.aeps-group.com.

© «AEPS-GROUP». All rights reserved.