

Features

- Up to 700 W output power, 24.7 W/in³
- Extreme case operating temp. range for request up to -50°C...+85°C
- Efficiency up to 93 %
- 174x92x29 (mm) milled case
- Input ranges:
230W - (100-242 VAC) - standard
230 - on request
- Power factor correction
- Output voltage adjustment
- Remote on/off
- External feedback
- Parallel operation
- Isolated OGOOD pins signaling output state readiness (on request)
- Isolated aux. output 12 VDC (FAN)
- Max output capacitance - not limited.
Constant current (CC) mode when charging output capacitance.

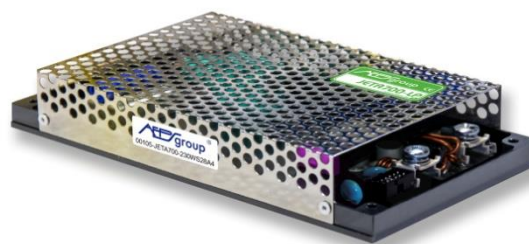

Description

JETA700-LP are the series of isolated AC/DC power supplies meant to work under both heavy electrical and environmental conditions for current projects using the previous generation of our units. Output power is **up to 700 Watts**, power density is up to **24.7 W/in³**. Standard functions include remote on/off and output voltage trimming. The units offer you flexibility of wide input and temperature ranges of **-40° to +85° C**. The units feature a system of over-current protection and over-voltage protection. Its versatility allows you to implement the converter in a vast number of industrial applications, supplying capacitive, constant-power and impulse load. Application fields: low-high altitude, land transport, supercomputers, mining, equipment in high and low temperature regions, digital signage equipment, APAR radars and others - where there are needed low-profile, low weight and high efficiency.

When ordering nominal power may be chosen from 300, 400, 500 and 700 W

One channel 700 W model*	Input voltage range**	Power max.	Output voltage nom.***	Output current max.	Efficiency typ.
JETA700-230WS12-SCx-LP-A4	100-242 VAC (1s 264 VAC transient) or DC equivalent	600 W	12 V	50.0 A	90 %
JETA700-230WS15-SCx-LP-A4		700 W	15 V	46.7 A	91 %
JETA700-230WS24-SCx-LP-A4		700 W	24 V	29.2 A	92 %
JETA700-230WS27-SCx-LP-A4		700 W	27 V	25.9 A	92 %
JETA700-230WS36-SCx-LP-A4		700 W	36 V	19.4 A	93 %
JETA700-230WS48-SCx-LP-A4		700 W	48 V	14.6 A	93 %
JETA700-230WS60-SCx-LP-A4		700 W	60 V	11.7 A	93 %

* Index of temperature range (instead of X): -40...+85° C (N), -50...+85° C (P);

** Units with different input voltage ranges, may be provided on request (please check the [selection guide](#)).

*** Models with custom output voltage may be provided on request.

General specifications		
Switching frequency		150 kHz typ. (PWM modulation)
Temperature ranges	operating case temp.	-40° C to +85° C (Standard "N" range)
	storage temp.	-60° C to +85° C
Over-temperature protection		+90° C typ.
Thermal mode and cooling method		conductive via heatsink
Humidity (non-condensing)		5-95 % rel. H
Insulation	input/case	1500 VAC
	input/output, input/REM	3000 VAC
	output/case, output/REM, REM/case	500 VAC
	output/output	500 VDC
Isolating resistance @ 500 VDC		>20 MOhm
Thermal shock, mechanical shock & vibration		MIL-STD-810F
Safety standards		IEC/EN 60950-1
Typical MTBF	$P_{out} = 0.7 \cdot P_{out,max}$	40 000 hrs (T _{case} = 50° C)
Weight (max)		1100 g
Input specifications		
Input voltage range (with power derating)	50 Hz	100-242 VAC (1s tran. 100-264 VAC)
	accepted DC	140-342 VDC (1s tran. 140-372 VDC)
Start-up input voltage		typ. 90 VAC
EMC standard compliance*	CE MIL-STD-461F, CE EN 55022 - class A (class B with JETA5 filter)	
Power Factor typ.		0.96
Harmonics of input current		EN61000-3-2, class D
Output specifications		
Power derating based on input voltage	linear derating from 700 to 500 W from 175 VAC to 100 VAC (for "230W" input)	
Output voltage adjustment	-20 % ... +5 % via internal trimmer ADJ or ±5 % via ADJ output (see drawing)	
Output voltage regulation	input variance U _{in,min} to U _{in,max}	±0.5 % for load 10-100 %
	load variance 10 % to 100 %	±2 %
Ripple and noise (peak-to-peak)	20 MHz bandwidth	<2 % for load 10-100 %
Protection	over-load	current source behavior: current is limited at 110-125 % of I _{out,nom}
	over-voltage	<130 % U _{out}
Capacitive load (max)		<i>not limited</i>
Remote Off	Unit is shut down by applying 3-5VDC (≤5 mA) to "+REM", "-REM" pins or by connecting "AUX" to "+REM."	
Isolated aux. output	FAN pins	9.5-13 VDC, 200 mA max
"OGOOD" function (on request)	open-collector. LOW resistance if U _{out} > 0,7*U _{out,nom} ; HIGH if U _{out} < 0,7*U _{out,nom} . U _{max} = 20 V, I _{max} = 15 mA	

* See product page for AC/DC filters at www.aeps-group.com.

Please contact the tech. team at aeps@aeps-group.cz for more information.

All specifications are valid for normal climatic conditions, nominal output voltage and current, unless otherwise stated.

Typical connection scheme (minimum required)

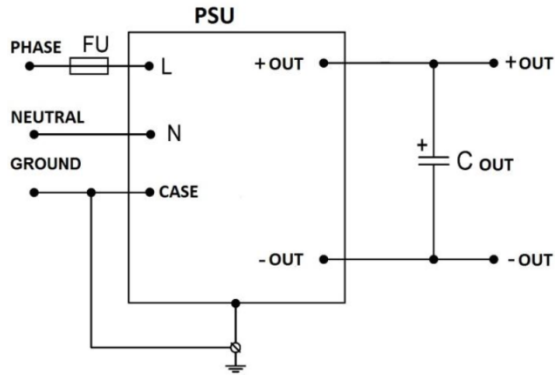

When using the units with typical connection scheme it's necessary to use certain type components.

C out values – please see point 5.6 in [Reference Technical Material](#) on our website.

Power-temperature relationship and cooling principles

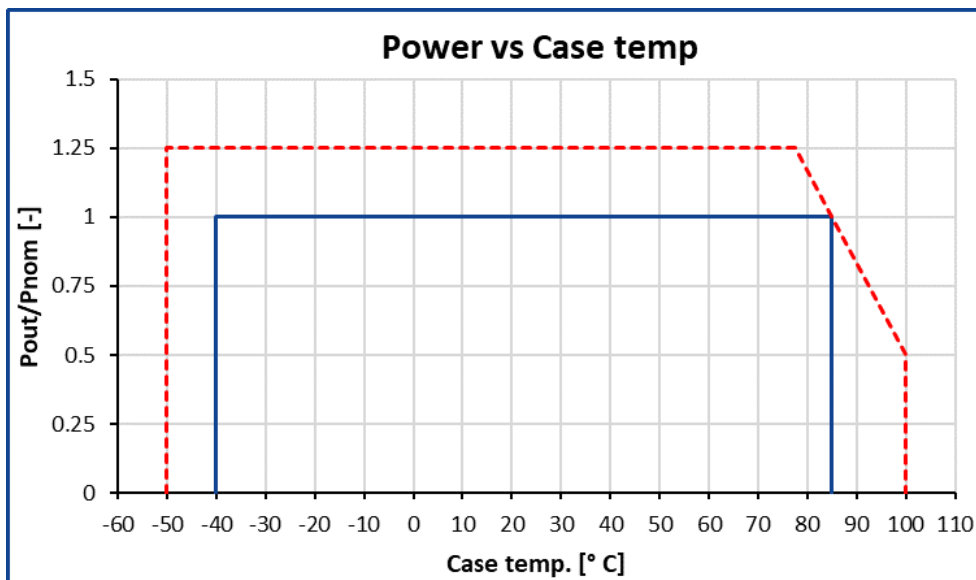

— Standard maximum power output based on case temperature.

- - - Possible range of output power for customized product.

Cooling method

The units don't include their own cooling system and may be operated only with a conductive (liquid) or convectional heatsink. Most of the unit's dissipated heat (93-95 %) is concentrated on the bottom surface of the unit, its base, which must be attached to the heatsink surface (aluminum or copper). Requirements for the heatsink surface (preferably milled) - flatness tolerance of the heatsink surface must be lower than 0.1 mm per 100 mm of length, with heatsink base at least 4 mm thick.

Unit's attachment to heatsink

When mounting the unit on a heatsink - screws tightening order should be following: first the central screw, then one pair of diagonally placed screws, then another pair of diagonally placed screws. First tightening of the screws should be done without force. Second tightening of the screws should be done with the recommended torque.

For quality contact between the unit and a heatsink - it's necessary to use thermal conductive paste with thickness less than 100 μm , with thermal conductivity greater than 2 $\text{W}/(\text{K}\cdot\text{m})$. Mesh stencil should be used to apply the paste in a pattern of squares (i.e. 2x2 mm to 4x4 mm squares mm with 0.5-1 mm spacing between the squares). This allows paste to be evenly spread in a thin layer and excess air to escape when tightening screws during unit mounting.

Short-term unit turn-on

If it's necessary to shortly turn on the unit for 3-5 minutes (for example for input-control testing), an aluminium (or copper) coldplate must be used as a heatsink. Its width and length must be not less than of the unit itself, with thickness at least 4 mm. It's prohibited to use the units without the specified coldplate.

MTBF based on case temperature

When using the unit, a customer must in one way or another monitor maximal heatsink temperature. Maximal heatsink temperature near the center point of the longer unit's side (considered as unit case temperature) must correspond to the expected unit's MTBF. Approximate MTBF function shown on the graph lower, where $\text{MTBF} / \text{MTBF}_{50}$ is unit's MTBF value at chosen unit's case operating temperature relative to value at 50°C unit's case temperature.

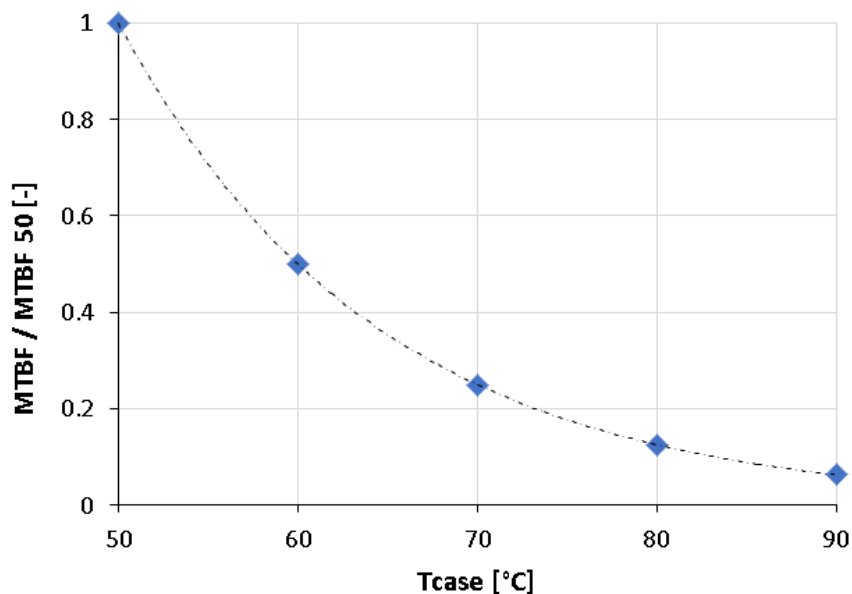

Thermal protection tripping

When internal unit's thermal protection is tripped (typ. +85°C ... +95°C) the unit is turned off (until automatic restart) and "OGOOD" outputs state becomes high-resistance (for models with OGOOD function). Such state should lead to measures of forced heatsink cooling, for example via fans turn-on. In case of long-term unit operation in such conditions (particularly in parallel connection modes or with close-to-zero loads) there is a possibility of failure due to frequent turning off and on at maximal unit's heatsink temperature. Time before automatic restart of the unit after thermal protection tripping can last from several seconds up to several minutes depending on thermal inertia of the heatsink.

Operation with shorted outputs

The units have a short-circuit output protection, which is for emergency only, not for long-term operation. It's prohibited to use the units with reversed input voltage polarity or turn on the units with short-circuited outputs (the units have the special detectors inside).

Reliability of parallel unit operation

To maximize reliability of parallel unit system (for case of failure of one parallel-connected units), while minus outputs (-OUT) are directly connected together - the pluses of the units (+OUT) should be connected through separating diodes. Usually, Schottky diodes with breakdown voltage at least twice of unit's output voltage are used for such purpose. PAR outputs of all parallel-connected units must be connected together.

If you have any questions please contact us directly at aeps@aeps-group.cz.

Dimensions

X1.1	X1.2	X1.3	X2.1	X2.2	X3.1	X3.2	X3.3	X3.4
GND	N	L	+OUT	-OUT	ADJ	PAR	+FAN	-FAN
X3.5	X3.6	X3.7	X3.8	X3.9	X3.10	X3.11	X3.12	
-RS	-OUT	+RS	+OUT	<i>n.a. / -OGOOD</i>	<i>n.a. / +OGOOD</i>	-REM	+REM	

X1	RATED WIRE SIZE SOLID: max.: 4 mm² Stranded (flexible): max.: 2.5 mm² Stranded with Ferrule: max 2.5 mm² Screw size: M3 Torque: 0,5 Nm
X2	Screw size: M5 Recommended torque: 2 Nm Recommended: Use ring terminal, for example MOLEX 19323-0013, MOLEX 19324-0013
X3	MOLEX, C-GRID III MALE – SDA-90130-1102. FEMALE – SD-90142-0012 (12 pin) USE WITH "CRIMP TERMINAL" SD – 90119-0109 or other. USE "HAND CRIMP TOOL" for C-GRID III female Crimp Terminals for example 63825-8100 or other depending on the CRIMP TERMINALS.

Dimensions in millimeters

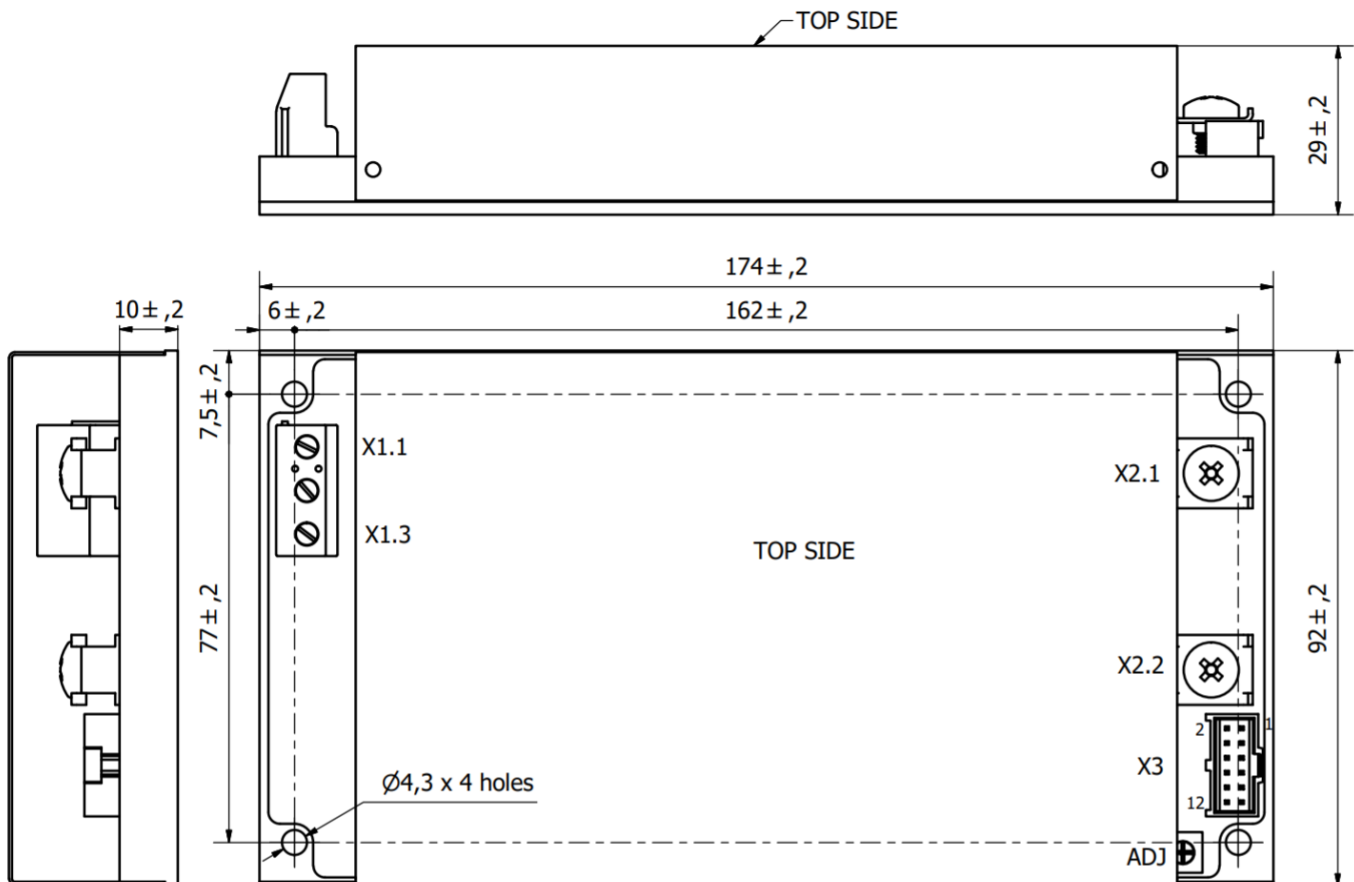

Additional information

After ordering the product - the customer is fully responsible for applying the product in strict compliance with mentioned rules and principles of use in the product datasheet and reference technical material (RTM) which is downloadable at www.aeps-group.com.

Please, note that all information in this material is for reference only. Further detailed information (including: additional requirements, manuals and circuit schemes) is found at www.aeps-group.com or provided via an email request at aeps@aeps-group.cz. All pictures shown are for illustration purpose only, actual product appearance may vary, incl. inner components choice and placement and connectors placement.

According to company's policy in view of constant improvements of the production design the manufacturer reserves the right to change the contents of specifications and promotional materials without prior notice! Make sure you are using the latest documentation downloadable at www.aeps-group.com.

© «AEPS-GROUP». All rights reserved.