

## Features

- Up to 120 W nominal output power, 14 W/in<sup>3</sup>
- Extreme case operating temp. range for request up to -50°C...+85°C
- Efficiency up to 89 %
- 111x61x21 (mm) metal case
- Variants input:  
230W - (100-242 VAC) - standard, other:  
115, 230



## Description

**JETA120** are the series of isolated AC/DC power supplies meant to work under both heavy electrical and environmental conditions for current projects using the previous generation of our units. Output power is **up to 120 Watts**, power density is up to **14 W/in<sup>3</sup>**. The units offer you flexibility of wide input range with both extremely low and high case temperatures of **-40° to +85° C**. The units feature a system of over-current and short-circuit protection and over-voltage protection. Its versatility allows you to implement the converter in a vast number of industrial applications, supplying capacitive, constant-power and impulse load. Application fields: low altitude, land transport, supercomputers, equipment in high-temperature regions, digital signage equipment, APAR radars and others - where there are needed low-profile, small size and weight, high efficiency.

### up to 120 W units (optimized for output power 36-96 W)

Model*	Input voltage range**	Power max.	Output voltage nom.***	Output current max.	Efficiency typ.
JETA120-230WS12-SCx	100-242 VAC (1s 264 VAC transient) or DC equivalent	120 W	12 V	10.0 A	84 %
JETA120-230WS15-SCx		120 W	15 V	8.0 A	85 %
JETA120-230WS24-SCx		120 W	24 V	5.0 A	87 %
JETA120-230WS27-SCx		120 W	27 V	4.4 A	88 %
JETA120-230WS48-SCx		120 W	48 V	2.5 A	89 %
JETA120-230WD1212-SCx	100-242 VAC (1s 264 VAC transient) or DC equivalent	120 W	±12 V	5.0 A	83 %
JETA120-230WD1515-SCx		120 W	±15 V	4.0 A	84 %
JETA120-230WD2424-SCx		120 W	±24 V	2.5 A	86 %
JETA120-230WD2727-SCx		120 W	±27 V	2.2 A	87 %
JETA120-230WD4848-SCx		120 W	±48 V	1.3 A	88 %

\* Index of temperature range (instead of X): -40...+85° C (N), -50...+85° C (P);

\*\* Units with different input voltage ranges, may be provided on request (please check the [selection guide](#)).

\*\*\* Models with custom output voltage may be provided on request.

General specifications		
Switching frequency		200 kHz typ. (PWM modulation)
Temperature ranges	operating case temp.	-40° C to +85° C (Standard "N" range)
	storage temp.	-60° C to +85° C
Over-temperature protection		+90° C typ.
Thermal mode and cooling method		conductive via heatsink or natural convection (consult with the producer first)
Thermal resistance	case-environment	4.8 K/W
Humidity (non-condensing)		5-95 % rel. H
Insulation	input/case	1500 VAC
	input/output	3000 VAC
	output/case	500 VAC
	output/output	500 VDC
Isolating resistance @ 500 VDC		>20 MOhm
Thermal shock, mechanical shock & vibration		MIL-STD-810F
Safety standards		IEC/EN 60950-1
Typical MTBF (Tcase = 50° C; Pout = 0.7·Pout,max)		50 000 hrs
Weight (max)		220 g
Input specifications		
Input voltage range (with power deration)	50 Hz	100-242 VAC (1s tran. 100-264 VAC)
	accepted DC	140-342 VDC (1s tran. 140-370 VDC)
Start-up input voltage		typ. 90 VAC
EMC standard compliance*		CE MIL-STD-461F, CE EN 55022 - class A (class B with JETA1 filter)
Output specifications		
Power deration based on input voltage	linear deration 120 to 60 W from 175 VAC to 100 VAC	
Output voltage adjustment	range	n.a.
Output voltage regulation	input variance Uin,min to Uin,max	±0.5 %
	load variance 10 % to 100 %	±2 %
Ripple and noise (peak-to-peak)	20 MHz bandwidth	<2 %
Protection	over-current and short-circuit	auto-reset into hiccup at 110-140 % of Iout,nom
	over-voltage	<130 % Uout
Capacitive load (max)	12 VDC output, 50% nominal Pout	typ. 20 000 uF
Minimum load	not required	
Remote Off	n.a.	

\* See product page for AC/DC filters at [www.aeps-group.com](http://www.aeps-group.com).

Please contact the tech. team at [aeps@aeps-group.cz](mailto:aeps@aeps-group.cz) for more information.

All specifications are valid for normal climatic conditions, nominal output voltage and current, unless otherwise stated.

## Typical connection scheme (minimum required)

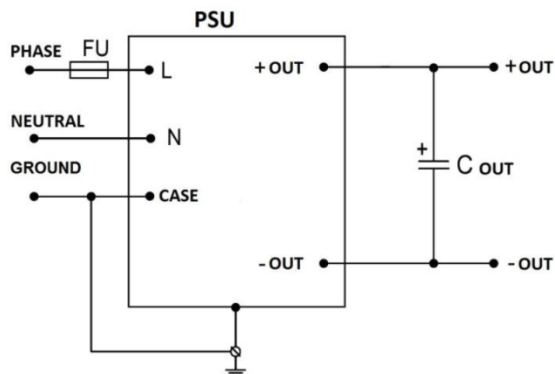

When using the units with typical connection scheme it's necessary to use certain type components.

C out values – please see point 5.6 in [Reference Technical Material](#).

Exact information can be found [Technical Materials](#) on our website [www.aeps-group.com](http://www.aeps-group.com)

## Max output power based on case temperature

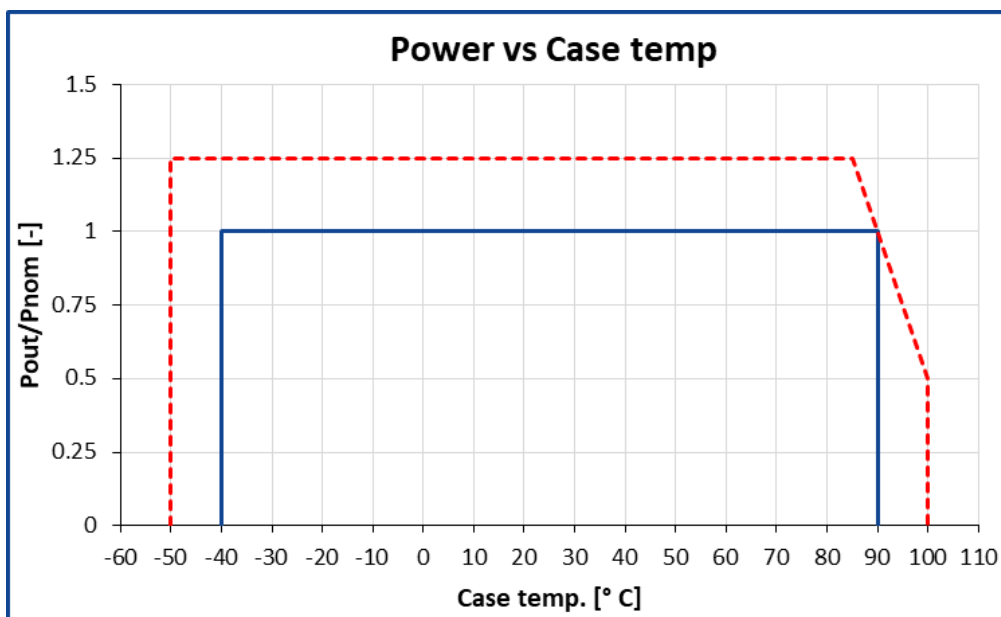

— Standard maximum power output based on case temperature.

- - - Possible range of output power for customized product.

The unit must be operated on a heatsink with thermal conductive paste applied between the unit surface and a heatsink for quality contact (with thickness less than 100  $\mu\text{m}$ , of minimal thermal resistance 2 W/K.m). Mesh stencil should be used to apply paste in a pattern of 2x2 mm to 4x4 mm squares mm with 0.5-1 mm spacing between the squares. This allows paste to be evenly spread in a thin layer and excess air to escape when tightening screws during unit mounting.

### Note:

The units have a short-circuit output protection, which is for emergency only, not for long-term operation. It's prohibited to use the units with reversed voltage polarity or turn on the units with short-circuited outputs (the units have the special detectors inside).

If you have any questions please contact us directly at [aeps@aeps-group.cz](mailto:aeps@aeps-group.cz).

## Dimensions

Pin #	X1.1	X1.2	X1.3	X2.1	X2.2	X2.3	X2.4	X2.5	X2.6
Single out	GND	L	N	+OUT	-OUT	-	-	-	-
Dual out	GND	L	N	+OUT1	+OUT1	-OUT1	-OUT1	+OUT2	-OUT2

<b>X1</b>	<b>RATED WIRE SIZE</b> <b>SOLID: max.: 3.3mm<sup>2</sup></b> <b>Stranded (flexible): max.: 3.3mm<sup>2</sup></b> <b>Stranded with Ferrule: max 3.3mm<sup>2</sup></b> <b>Screw size: M3</b> <b>Torque: 0,5 Nm</b>
<b>X2</b>	<b>Screw size: 6-32 x 1/4L</b> <b>Recommended torque: 0.5Nm</b> <b>Recommended: Use ring terminal, for example</b> <b>MOLEX 19323-0007, MOLEX 19324-0007</b>  <b><u>OR same spec as X1 for Dual Models</u></b>

Dimensions in millimeters

### Single Output

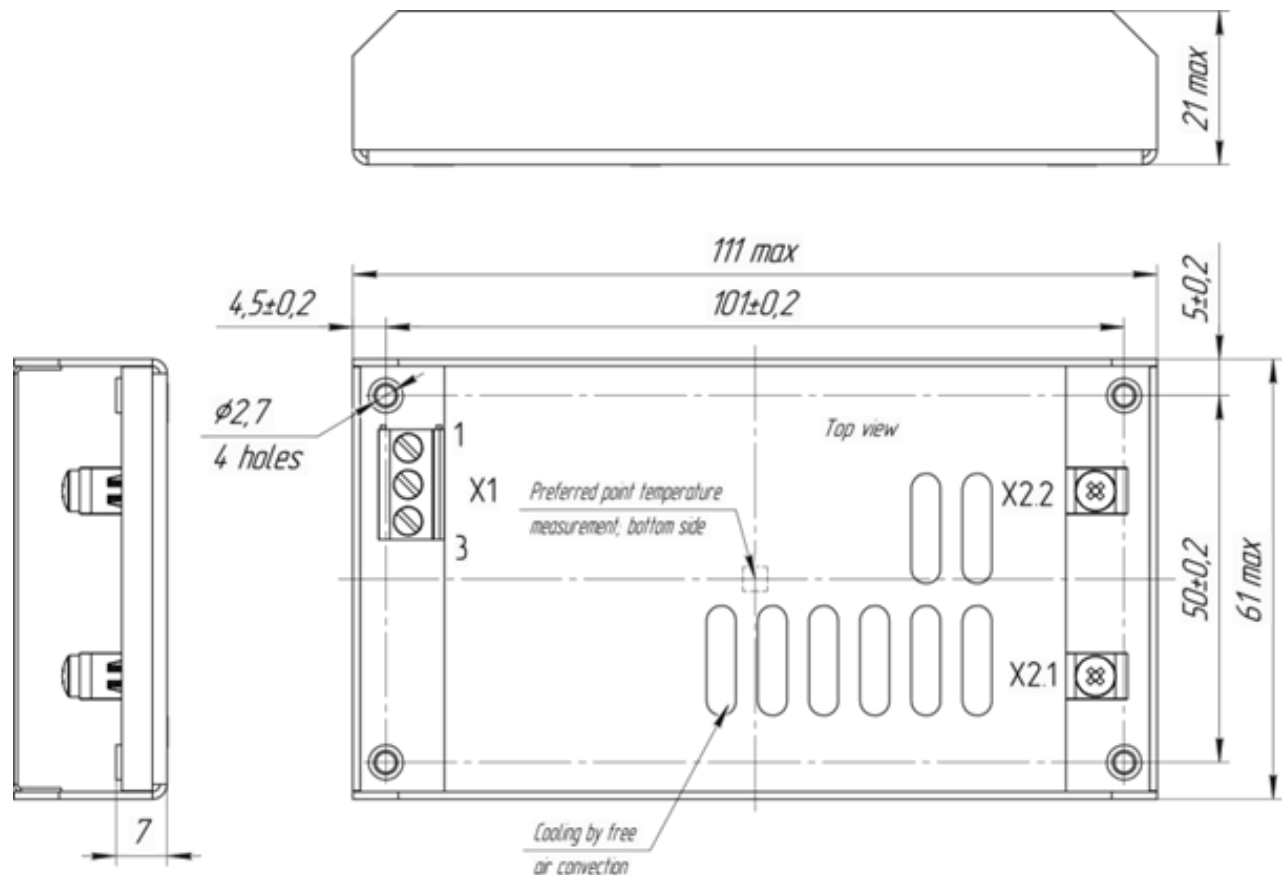

## Dual output

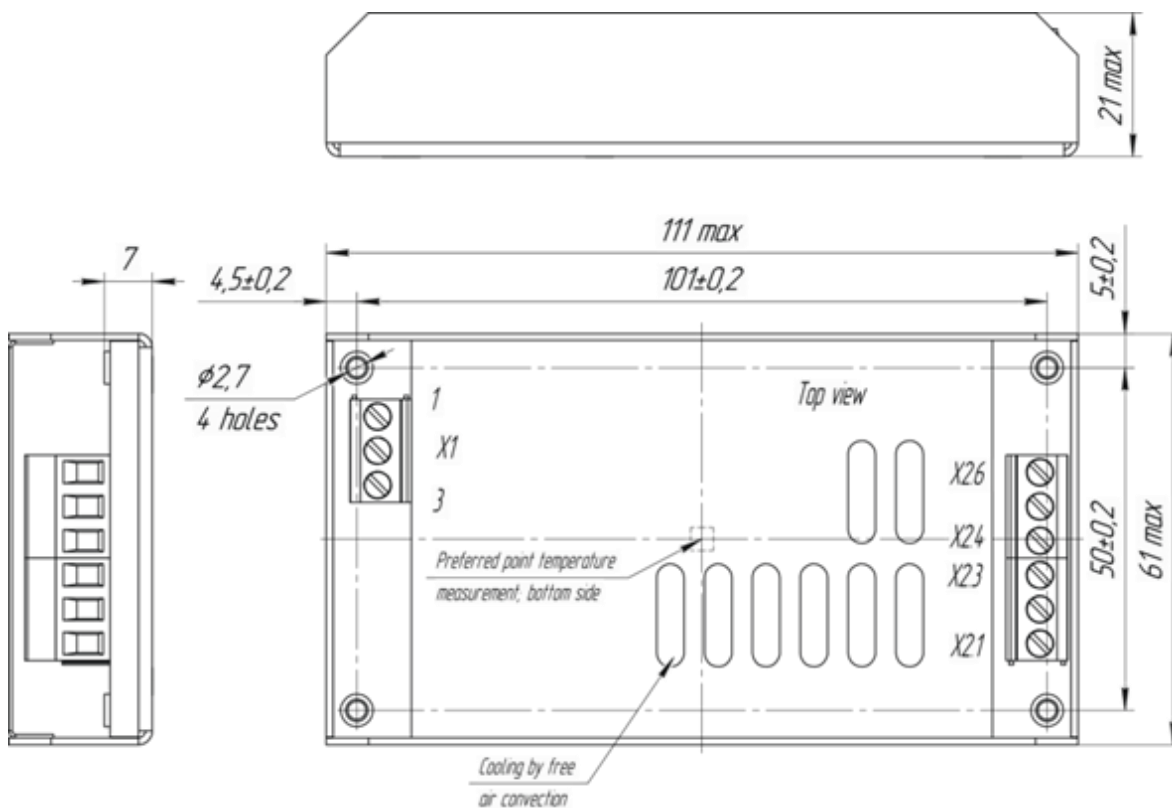

## DIN rail mounting

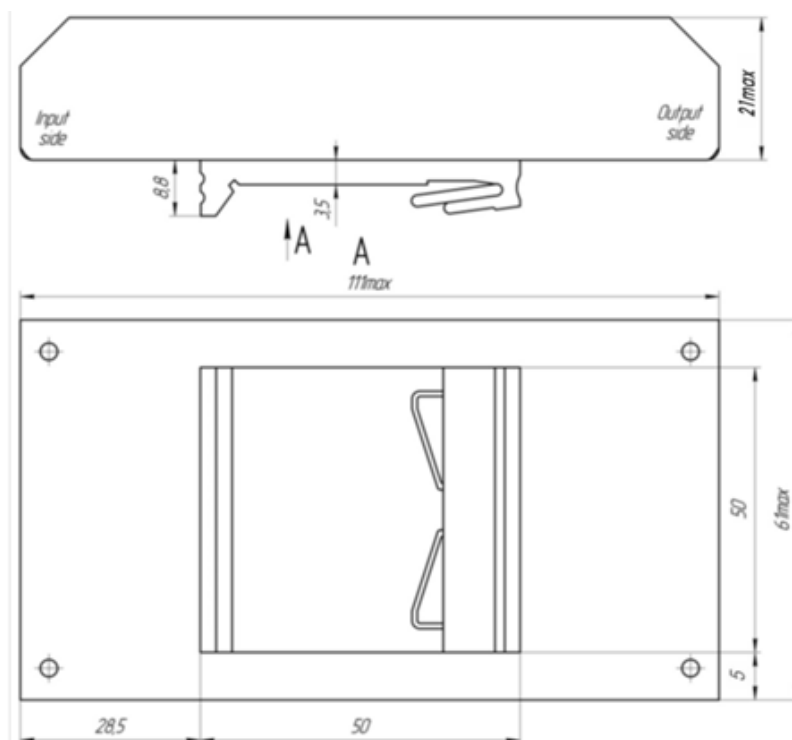

## Additional information

Please, note that all information in this material is for reference only. Further detailed information (including: additional requirements, manuals and circuit schemes) is found at [www.aeps-group.com](http://www.aeps-group.com) or provided via an email request at [aeps@aeps-group.cz](mailto:aeps@aeps-group.cz). All pictures shown are for illustration purpose only, actual product appearance may vary, incl. inner components choice and placement and connectors placement.

According to company's policy in view of constant improvements of the production design the manufacturer reserves the right to change the contents of specifications and promotional materials without prior notice! Make sure you are using the latest documentation downloadable at [www.aeps-group.com](http://www.aeps-group.com).

© «AEPS-GROUP». All rights reserved.