

## Features

- Up to 10 W output power, 27 W/in<sup>3</sup>
- **Feedback without optocoupling**
- Output voltage possible up to 150 VDC on request
- Additional input and output filter (MIL-461)
- Extreme case operating temp. range for request up to -60...+130 °C
- Efficiency up to 87 %
- 30x20x10 (mm) aluminium case (dim. without flanges) with **pin-side shielding**
- Input ranges:  
"27W" - (15-50 VDC) - standard
- Output voltage adjustment
- Remote on/off

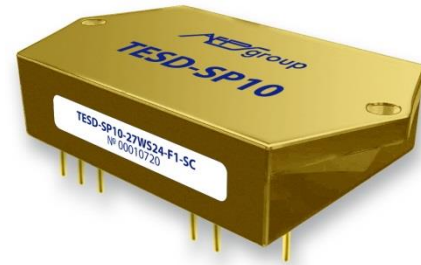

## Description

TESD-SP-10-F1 are the series of isolated DC/DC converters **with no-optocoupler feedback and pin-side shielding**. The units include additional input and output EMC filters. Output power up to 10 Watts, power density up to 27 W/in<sup>3</sup>. Operational in wide input voltage range and at wide temperature range of standard -60° to +110° C. The units feature a full system of protections and service functions including remote on/off and output voltage trimming. Lack of internal empty spaces and materials, which produce gases when used in vacuum, allows to apply TESD-SP units at heights up to "near-space".

series TESD-SP					
One channel 10 W model*	Input voltage range**	Power max.	Output voltage nom.***	Output current max.	Efficiency typ.
TESD-SP-10-27WS05-F1-xC	15-50 VDC (80 VDC 1s transient)	10 W	05 V	2.00 A	83 %
TESD-SP-10-27WS12-F1-xC		10 W	12 V	0.83 A	85 %
TESD-SP-10-27WS15-F1-xC		10 W	15 V	0.67 A	85 %
TESD-SP-10-27WS24-F1-xC		10 W	24 V	0.42 A	85 %
TESD-SP-10-27WS27-F1-xC		10 W	27 V	0.37 A	85 %
TESD-SP-10-27WS36-F1-xC		10 W	36 V	0.28 A	86 %
TESD-SP-10-27WS48-F1-xC		10 W	48 V	0.21 A	86 %
TESD-SP-10-27WS60-F1-xC		10 W	60 V	0.17 A	87 %

\* Index of temperature range (instead of X): -60...+110 °C (M), -60...+130 °C (E)

\*\* Units with different input voltage ranges, may be provided on request (please check the [selection guide](#)).

\*\*\* Models with custom output voltage may be provided on request.

series TESP-SP					
Dual channel 10 W model*	Input voltage range**	Power max.	Output voltage nom.***	Output current max. per channel	Efficiency typ.
TESD-SP-10-27WD0505-F1-xC	15-50 VDC (80 VDC 1s transient)	10 W	2 x 05 V	1.00 A	82 %
TESD-SP-10-27WD1212-F1-xC		10 W	2 x 12 V	0.42 A	84 %
TESD-SP-10-27WD1515-F1-xC		10 W	2 x 15 V	0.33 A	84 %
TESD-SP-10-27WD2424-F1-xC		10 W	2 x 24 V	0.21 A	84 %
TESD-SP-10-27WD2727-F1-xC		10 W	2 x 27 V	0.19 A	84 %
TESD-SP-10-27WD3636-F1-xC		10 W	2 x 36 V	0.14 A	85 %
TESD-SP-10-27WD4848-F1-xC		10 W	2 x 48 V	0.10 A	85 %
TESD-SP-10-27WD6060-F1-xC		10 W	2 x 60 V	0.08 A	86 %

\* Index of temperature range (instead of X): -60...+110 °C (M), -60...+130 °C (E)

\*\* Units with different input voltage ranges, may be provided on request (please check the [selection guide](#)).

\*\*\* Models with custom output voltage may be provided on request.

General specifications		
Switching frequency		400 kHz typ. (PWM modulation)
Temperature ranges	operating case temp.	-40 °C to +110 °C (Standard "S" range)
	storage temp.	-60 °C to +130 °C
Over-temperature protection		+115 °C typ.
Thermal mode and cooling method		conductive via heatsink or natural convection
Thermal resistance, case-ambient	natural convection	18 K/W typ.
Humidity (non-condensing)		5-95 % rel. H
Insulation	input/case, input/output	1500 VDC
	output/case	1000 VDC
	output/output	500 VDC
Isolating resistance @ 500 VDC		>20 MOhm
Thermal shock, mechanical shock & vibration		MIL-STD-810F
Safety standards		IEC/EN 60950-1
Typical MTBF	$P_{out} = 0.7 \cdot P_{out.max}$	190 000 hrs (T <sub>case</sub> = 50 °C)
Weight (max)		17 g
Input specifications		
Input voltage range	range "27W"	15-50 VDC (80 VDC 1s transient)
Start-up input voltage		12-15 VDC
EMC standard compliance*	CE MIL-STD-461F, with typical connection scheme, use JETDF2.5 to improve filtration	
Output specifications		
Output voltage adjustment	in range $\pm 5$ %, via ADJ output (see drawing)	
Output voltage regulation**	input variance U <sub>in,min</sub> to U <sub>in,max</sub>	$\pm 0.5$ % for load 10-100 %
	load var. 10 % to 100 %	$\pm 2$ %
Ripple and noise (peak-to-peak)	20 MHz bandwidth	<2 % for load 10-100 %

Protection	over-load	auto-reset at 110-150 % of $I_{out,nom}$
	over-voltage	<130 % $U_{out}$
Capacitive load (max)	24 VDC output (50% $P_{out}$ ) - typ. 1 300 $\mu F$	
Remote Off	connect ON to -IN or apply 0-0.5 VDC to ON	

\* See product page for DC/DC filters at [www.aeps-group.com](http://www.aeps-group.com).

\*\* When varying load in the main stabilized channel from 10 % to 100 %, secondary output voltage regulation may reach  $\pm 13$  %

Please contact the tech. team at [aeps@aeps-group.cz](mailto:aeps@aeps-group.cz) for more information.

All specifications are valid for normal climatic conditions, nominal output voltage and current, unless otherwise stated.

## Typical connection scheme (minimum required)

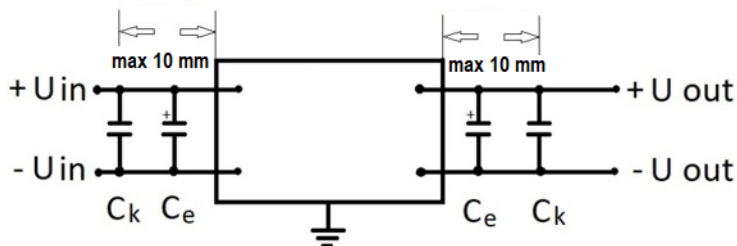

The design of the units allows their use only when mounted on a PCB. It's necessary to use certain type components. In the figure:  $C_k$  – ceramic capacitors of a certain operating voltage and of several  $\mu F$  capacity;  $C_e$  – electrolytic capacitors of a certain operating voltage and of polymer, aluminum or tantalum type of tens to hundreds  $\mu F$  capacity. For component values – please see point 5.5 in [Reference Technical Material for DC/DC units](#).

hundreds  $\mu F$  capacity. For component values – please see point 5.5 in [Reference Technical Material for DC/DC units](#).

## Max output power based on case temperature

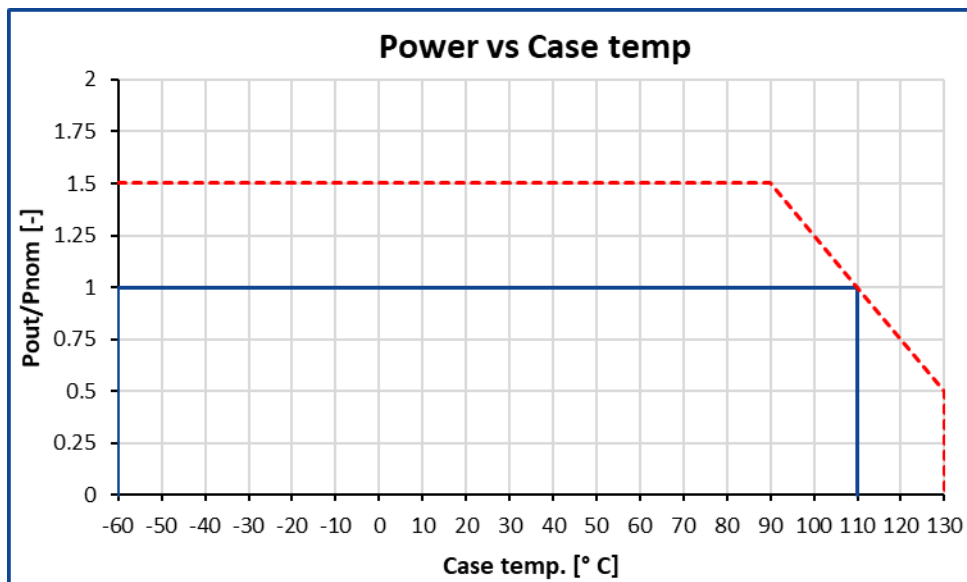

— Standard maximum power output based on case temperature.

- - - Possible range of output power for customized product.

Before operation, the product label on converter top side has to be removed.

If chosen cooling method is conduction, the unit must be operated on a heatsink with thermal conductive paste applied between the unit surface and a heatsink for quality contact (with thickness less than 100  $\mu m$ , with thermal conductivity greater than 2 W/K.m). Mesh stencil should be used to apply paste in a pattern of 2x2 mm to 4x4 mm squares mm with 0.5-1 mm spacing between the squares. This allows paste to be evenly spread in a thin layer and excess air to escape when tightening screws during unit mounting.

**Note:**

The units have a short-circuit output protection, which is for emergency only, not for long-term operation. It's prohibited to use the units with reversed input voltage polarity or turn on the units with short-circuited outputs (the units have the special detectors inside).

## Max output power based on ambient temperature

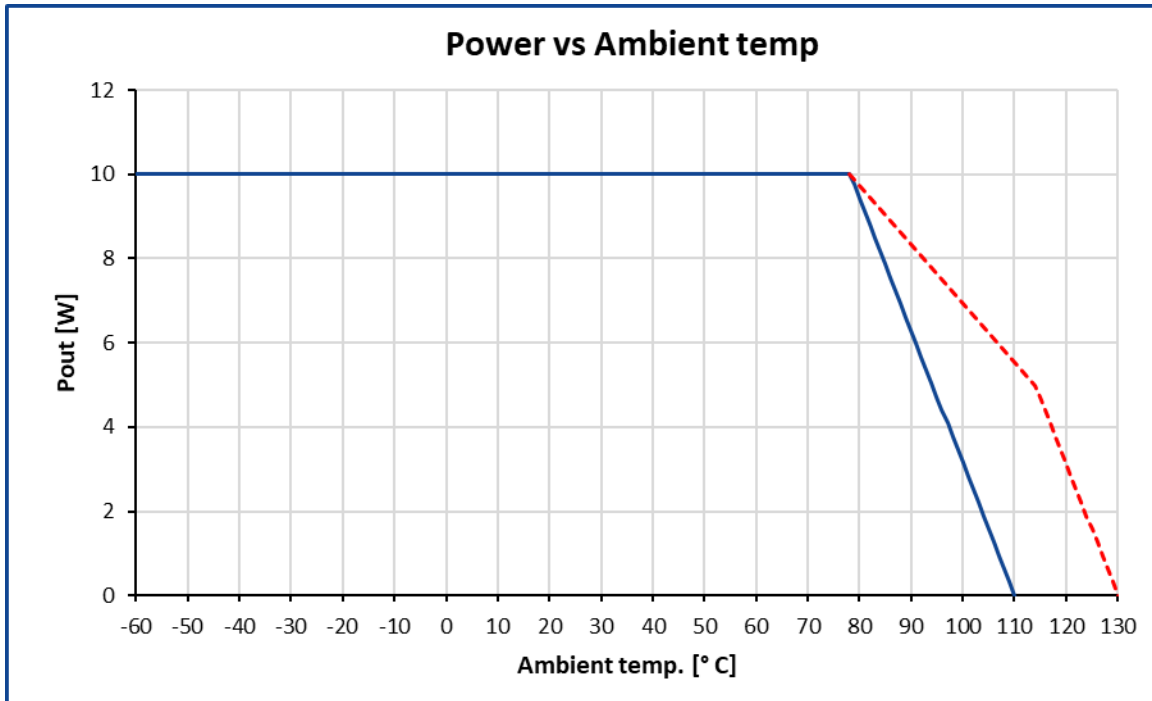

— for temperature range up to +110 °C

- - - for temperature range up to +130 °C

The graph is constructed for a 10 W model with 85% efficiency.

Before operation, the product label on converter top side has to be removed.

When using the unit without heatsink it's assumed that the units are located on a vertically-oriented PCB that does not have any other significant heat sources other than the units themselves. It is allowed to use the units on a horizontally-oriented PCB when placing the units on the upper side. In any case, it is necessary to provide unrestricted air convection around the units.

**Note:**

The units have a short-circuit output protection, which is for emergency only, not for long-term operation. It's prohibited to use the units with reversed input voltage polarity or turn on the units with short-circuited outputs (the units have the special detectors inside).

If you have any questions please contact us directly at [aeps@aeps-group.cz](mailto:aeps@aeps-group.cz).

## MTBF based on case temperature

When using the unit, a customer must in one way or another monitor maximal heatsink temperature. Maximal heatsink temperature near the center point of the longer unit's side (considered as unit case temperature) must correspond to the expected unit's MTBF. Approximate MTBF function shown on the graph lower, where  $MTBF / MTBF_{50}$  is unit's MTBF value at chosen unit's case operating temperature relative to value at 50°C unit's case temperature.

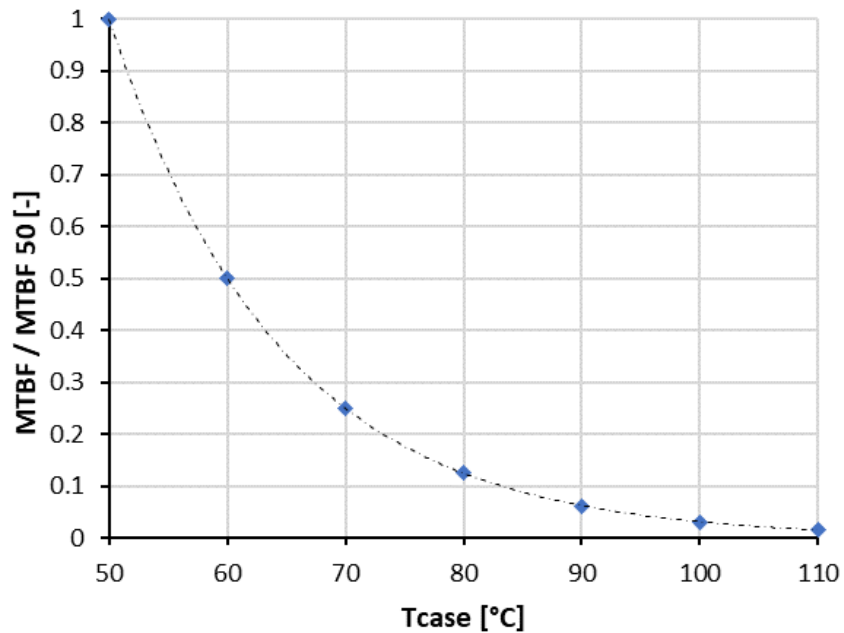

## Dimensions

Pin #	1,2	3	4	5	6	7	8	9,10	11
Single ch.	-IN	ON	n.u.	n.u.	+OUT	ADJ	-OUT	+IN	CASE
Dual ch.	-IN	ON	+OUT2	-OUT2	+OUT1	n.u.	-OUT1	+IN	CASE

Dimensions in millimeters, 2 installation holes, PCB mounting only

### Single channel

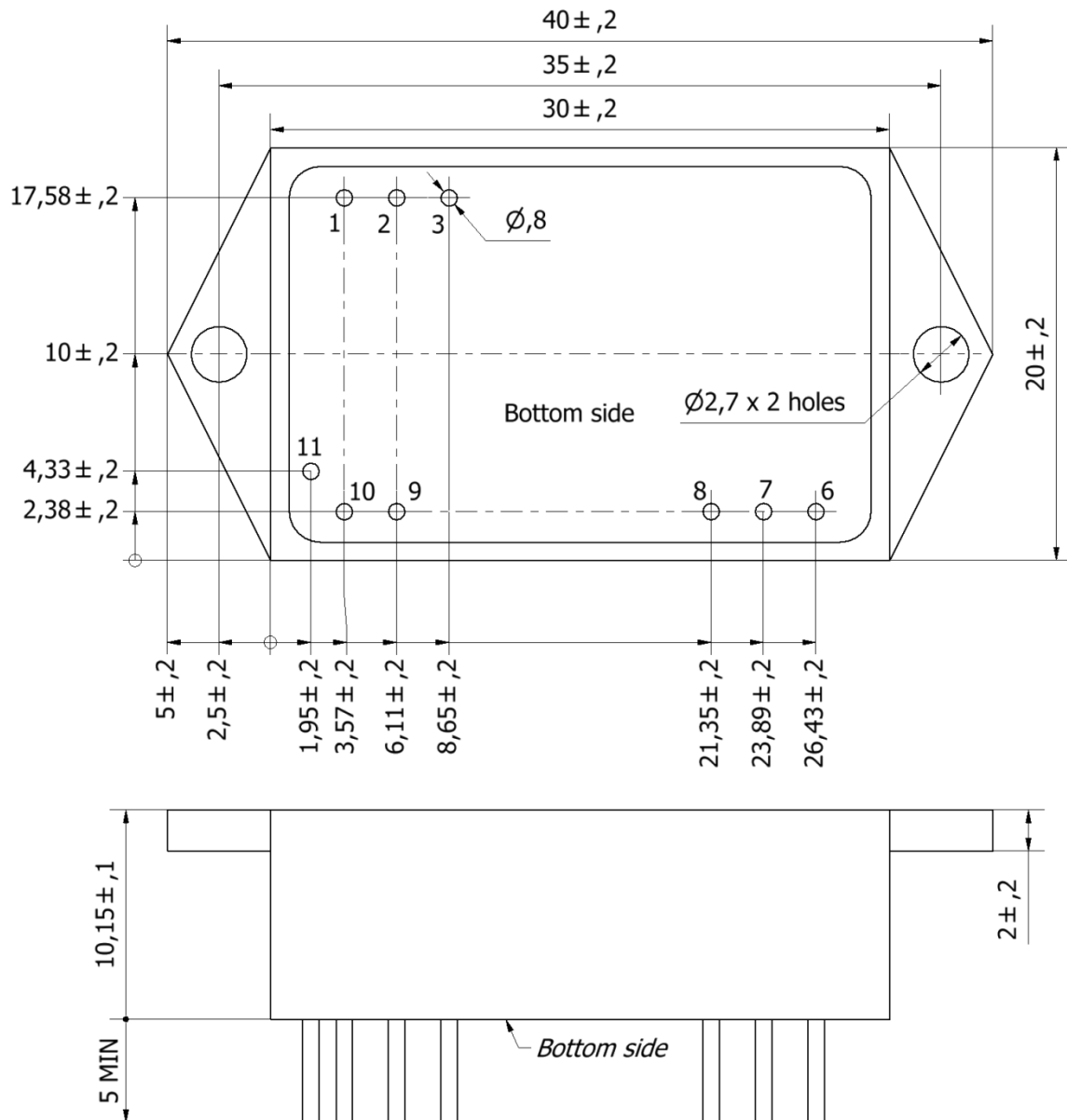

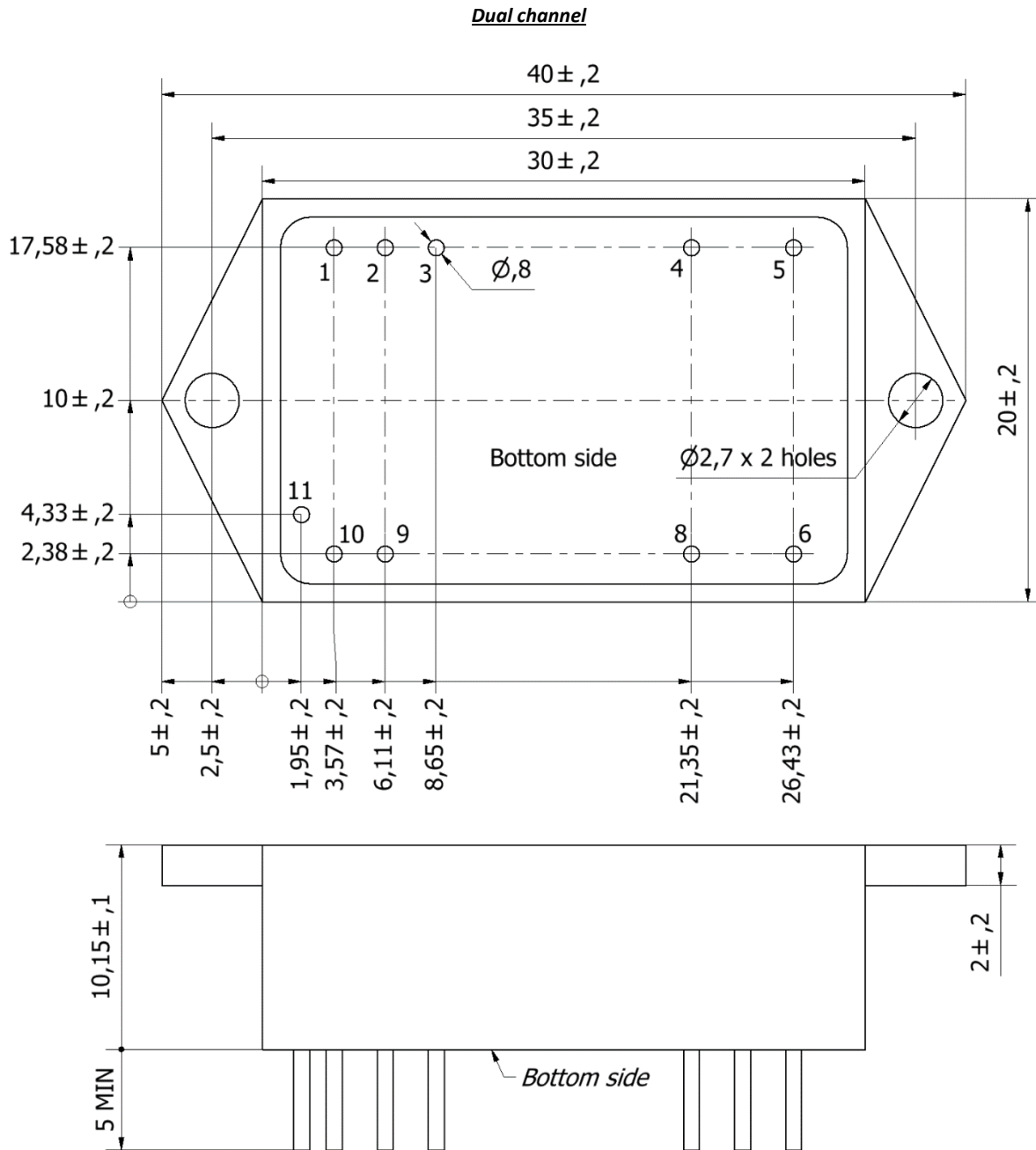

## Additional information

After ordering the product - the customer is fully responsible for applying the product in strict compliance with mentioned rules and principles of use in the product datasheet and reference technical material (RTM) which is downloadable at [www.aeps-group.com](http://www.aeps-group.com).

Please, note that all information in this material is for reference only. Further detailed information (including: additional requirements, manuals and circuit schemes) is found at [www.aeps-group.com](http://www.aeps-group.com) or provided via an email request at [aeps@aeps-group.cz](mailto:aeps@aeps-group.cz). All pictures shown are for illustration purpose only, actual product appearance may vary, incl. inner components choice and placement and connectors placement.

According to company's policy in view of constant improvements of the production design the manufacturer reserves the right to change the contents of specifications and promotional materials without prior notice! Make sure you are using the latest documentation downloadable at [www.aeps-group.com](http://www.aeps-group.com).

© «AEPS-GROUP». All rights reserved.