

## Features

- Up to 300 W nominal output power, 16 W/in<sup>3</sup>
- Case operating temp. range -40°C...+85°C
- Efficiency up to 93 %
- 134x84x27.5 (mm) metal case
- Input ranges:  
230W - (100-242 VAC) - standard, other:  
230
- Power factor correction
- Output voltage trimming
- Remote on/off
- One or two galvanically isolated outputs
- Ability to achieve increased output voltage via serial connection of outputs



## Description

**JETAs300** are the series of isolated AC/DC power supplies meant to work under both heavy electrical and environmental conditions. Output power is **up to 300 Watts**, power density is up to **16 W/in<sup>3</sup>**. The units offer you flexibility of wide input and temperature ranges of **-40° to +85° C**. The units feature a system of over-current protection and over-voltage protection. Its versatility allows you to implement the converter in a vast number of industrial applications, supplying capacitive, constant-power and impulse load. Application fields: low-high altitude, land transport, supercomputers, mining, equipment in high and low temperature regions, digital signage equipment, APAR radars and others - where there are needed low-profile, low weight and high efficiency.

series JETAs					
One channel 300 W model*	Input voltage range**	Power max.	Output voltage nom.***	Output current max.	Efficiency typ.
JETAs300-230WS05-SCN-A3	100-242 VAC (1s 264 VAC transient) or DC equivalent	150 W	05 V	30.0 A	88 %
JETAs300-230WS12-SCN-A3		300 W	12 V	25.0 A	90 %
JETAs300-230WS15-SCN-A3		300 W	15 V	20.0 A	91 %
JETAs300-230WS24-SCN-A3		300 W	24 V	12.5 A	92 %
JETAs300-230WS27-SCN-A3		300 W	27 V	11.1 A	92 %
JETAs300-230WS36-SCN-A3		300 W	36 V	8.3 A	93 %
JETAs300-230WS48-SCN-A3		300 W	48 V	6.3 A	93 %
JETAs300-230WS60-SCN-A3		300 W	60 V	5.0 A	93 %

\*\* Units with different input voltage ranges, may be provided on request (please check the [selection guide](#)).

\*\*\* Models with custom output voltage may be provided on request.

series JETAs					
Dual channel 300 W model*	Input voltage range**	Power max.	Output voltage nom.***	Output current max. per channel	Efficiency typ.
JETAs300-230WD0505-SCN-A3	100-242 VAC (1s 264 VAC transient) or DC equivalent	150 W	2 x 05 V	15.0 A	84 %
JETAs300-230WD1212-SCN-A3		300 W	2 x 12 V	12.5 A	85 %
JETAs300-230WD1515-SCN-A3		300 W	2 x 15 V	10.0 A	86 %
JETAs300-230WD2424-SCN-A3		300 W	2 x 24 V	6.3 A	87 %
JETAs300-230WD2727-SCN-A3		300 W	2 x 27 V	5.6 A	87 %
JETAs300-230WD3636-SCN-A3		300 W	2 x 36 V	4.2 A	87 %
JETAs300-230WD4848-SCN-A3		300 W	2 x 48 V	3.1 A	87 %
JETAs300-230WD6060-SCN-A3		300 W	2 x 60 V	2.5 A	88 %

\*\* Units with different input voltage ranges, may be provided on request (please check the [selection guide](#)).

\*\*\* Models with custom output voltage may be provided on request.

General specifications		
Switching frequency		200 kHz typ. (PWM modulation)
Temperature ranges	operating case temp.	-40° C to +85° C (Standard "N" range)
	storage temp.	-60° C to +85° C
Over-temperature protection		+90° C typ.
Thermal mode and cooling method		conductive via heatsink or natural convection (consult with the producer first)
Thermal resistance	case-environment	2.7 K/W
Humidity (non-condensing)		5-95 % rel. H
Insulation	input/case	1500 VAC
	input/output, input/REM	3000 VAC
	output/case, output/REM, REM/case	500 VAC
	output/output	500 VDC
Isolating resistance @ 500 VDC		>20 MOhm
Thermal shock, mechanical shock & vibration		MIL-STD-810F
Safety standards		IEC/EN 60950-1
Typical MTBF	$P_{out} = 0.7 \cdot P_{out,max}$	40 000 hrs (T <sub>case</sub> = 50° C)
Weight (max)		500 g
Input specifications		
Input voltage range (with power derating)	50 Hz	100-242 VAC (1s tran. 100-264 VAC)
	accepted DC	140-342s VDC (1s tran. 140-372 VDC)
Start-up input voltage		typ. 90 VAC
EMC standard compliance*	CE MIL-STD-461F, CE EN 55022 - class A (class B with JETA5 filter)	
Power Factor typ.		0.96
Harmonics of input current		EN61000-3-2, class D

\* See product page for AC/DC filters at [www.aeps-group.com](http://www.aeps-group.com).

## Output specifications

Power derating based on input voltage	linear derating from 300 to 175 W from 175 VAC to 100 VAC (for "230W" input)	
Output voltage adjustment	-20 % ... +5 % via internal trimmer ADJ (see drawing)	
Output voltage regulation**	input variance $U_{in,min}$ to $U_{in,max}$	$\pm 0.5$ % for load 10-100 %
	load variance 10 % to 100 %	$\pm 2$ %
Ripple and noise (peak-to-peak)	20 MHz bandwidth	<2 % for load 10-100 %
Protection	over-load	auto-reset at 110-140 % of $I_{out,nom}$
	over-voltage	<130 % $U_{out}$
Capacitive load (max)	24 VDC output, 50% nominal $P_{out}$	typ. 19 000 $\mu F$
Remote Off	Unit is shut down by applying 3-5VDC ( $\leq 5$ mA) to "+REM", "-REM" pins	

Please contact the tech. team at [aeps@aeps-group.cz](mailto:aeps@aeps-group.cz) for more information.

\*\* When varying load in the main stabilized channel from 10 % to 100 %, secondary output voltage regulation may reach  $\pm 13$  %  
All specifications are valid for normal climatic conditions, nominal output voltage and current, unless otherwise stated.

## Typical connection scheme (minimum required)

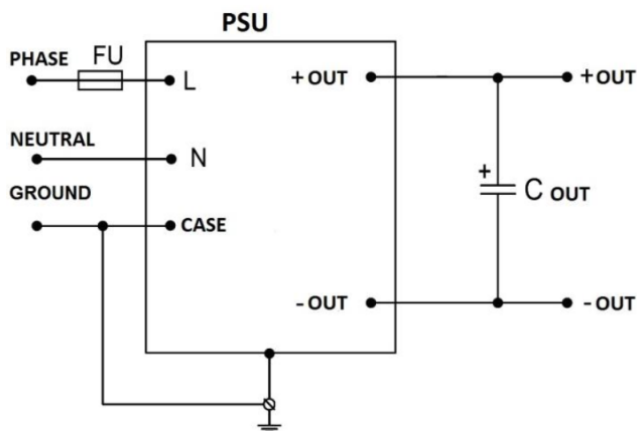

When using the units with typical connection scheme it's necessary to use certain type components.

$C_{out}$  values – please see point 5.6 in [Reference Technical Material](#) on our website.

## Power-temperature relationship and cooling principles

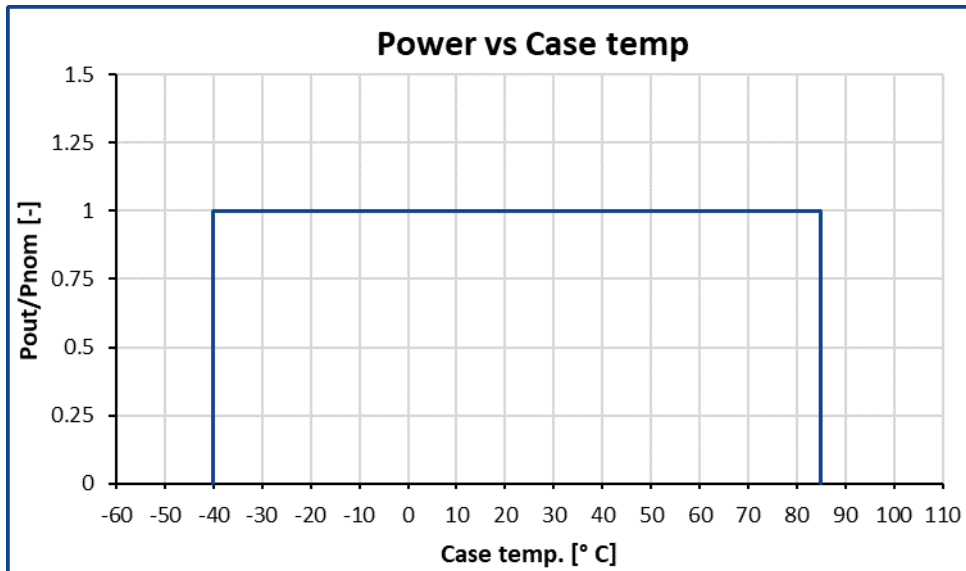

— Standard maximum power output based on case temperature.

### Cooling method

The units don't include their own cooling system and are meant to be operated with a conductive (liquid) or convectional heatsink. Most of the unit's dissipated heat (93-95 %) is concentrated on the bottom surface of the unit, its base, which should be attached to the heatsink surface (aluminum or copper). Requirements for the heatsink surface (preferably milled) - flatness tolerance of the heatsink surface must be lower than 0.1 mm per 100 mm of length. For unit application without heatsink it's required to consult with the producer.

### Unit's attachment to heatsink

When mounting the unit on a heatsink - screws tightening order should be following: first the central screw, then one pair of diagonally placed screws, then another pair of diagonally placed screws. First tightening of the screws should be done without force. Second tightening of the screws should be done with the recommended torque.

For quality contact between the unit and a heatsink - it's necessary to use thermal conductive paste with thickness less than 100  $\mu\text{m}$ , with thermal conductivity greater than 2 W/(K.m). Mesh stencil should be used to apply the paste in a pattern of squares (i.e. 2x2 mm to 4x4 mm squares mm with 0.5-1 mm spacing between the squares). This allows paste to be evenly spread in a thin layer and excess air to escape when tightening screws during unit mounting.

### Short-term unit turn-on

If it's necessary to shortly turn on the unit for 3-5 minutes (for example for input-control testing), an aluminium (or copper) coldplate may be used as a heatsink. Its width and length must be not less than of the unit itself, with thickness at least 2 mm.

## MTBF based on case temperature

When using the unit, a customer must in one way or another monitor maximal heatsink temperature. Maximal heatsink temperature near the center point of the longer unit's side (considered as unit case temperature) must correspond to the expected unit's MTBF. Approximate MTBF function shown on the graph lower, where MTBF / MTBF 50 is unit's MTBF value at chosen unit's case operating temperature relative to value at 50°C unit's case temperature.

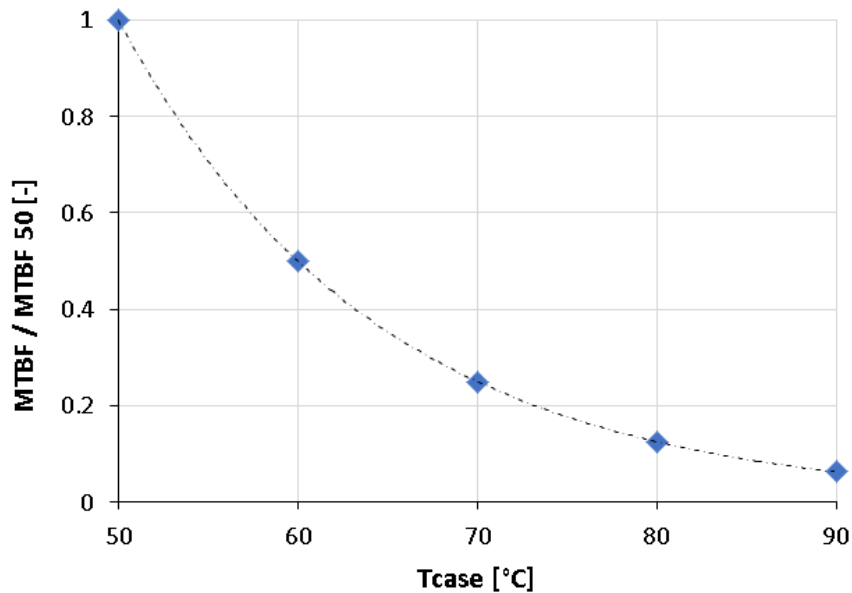

## Thermal protection tripping

When internal unit's thermal protection is tripped (typ. +85°C ... +95°C) the unit is turned off (until automatic restart). Such state should lead to measures of forced heatsink cooling, for example via fans turn-on. In case of long-term unit operation in such conditions (particularly in case with close-to-zero loads) there is a possibility of failure due to frequent turning off and on at maximal unit's heatsink temperature. Time before automatic restart of the unit after thermal protection tripping can last from several seconds up to several minutes depending on thermal inertia of the heatsink.

## Operation with shorted outputs

The units have a short-circuit output protection, which is for emergency only, not for long-term operation. It's prohibited to use the units with reversed input voltage polarity or turn on the units with short-circuited outputs (the units have the special detectors inside).

If you have any questions please contact us directly at [aeps@aeps-group.cz](mailto:aeps@aeps-group.cz).

## Dimensions

Pin #	X1.1	X1.2	X1.3	X2.1	X2.2	X2.3	X2.4	X3.1	X3.2
Single ch.	GND	N	L	+OUT	-OUT	-	-	+REM	-REM
Dual ch.	GND	N	L	-OUT1	+OUT1	-OUT2	+OUT2	+REM	-REM

<b>X1</b>	<b>RATED WIRE SIZE</b> <b>SOLID: max.: 4mm<sup>2</sup></b> <b>Stranded (flexible): max. 2.5mm<sup>2</sup></b> <b>Stranded with Ferrule: max 2.5mm<sup>2</sup></b> <b>Screw size: M3</b> <b>Torque: 0,5 Nm</b>
<b>X2</b>	<b>Screw size: M4</b> <b>Recommended torque: 1.2Nm</b> <b>Recommended: Use ring terminal, for example</b> <b>MOLEX 19323-0012, MOLEX 19324-0012</b>  <b><u>OR same spec as X1 for Dual Models</u></b>
<b>X3</b>	<b>RATED WIRE SIZE</b> <b>SOLID: max.: 1.5 mm<sup>2</sup></b> <b>Flexible: max.: 1.5 mm<sup>2</sup></b> <b>with Ferrule: max 0.75 mm<sup>2</sup></b>

Dimensions in millimetres

### Single Output

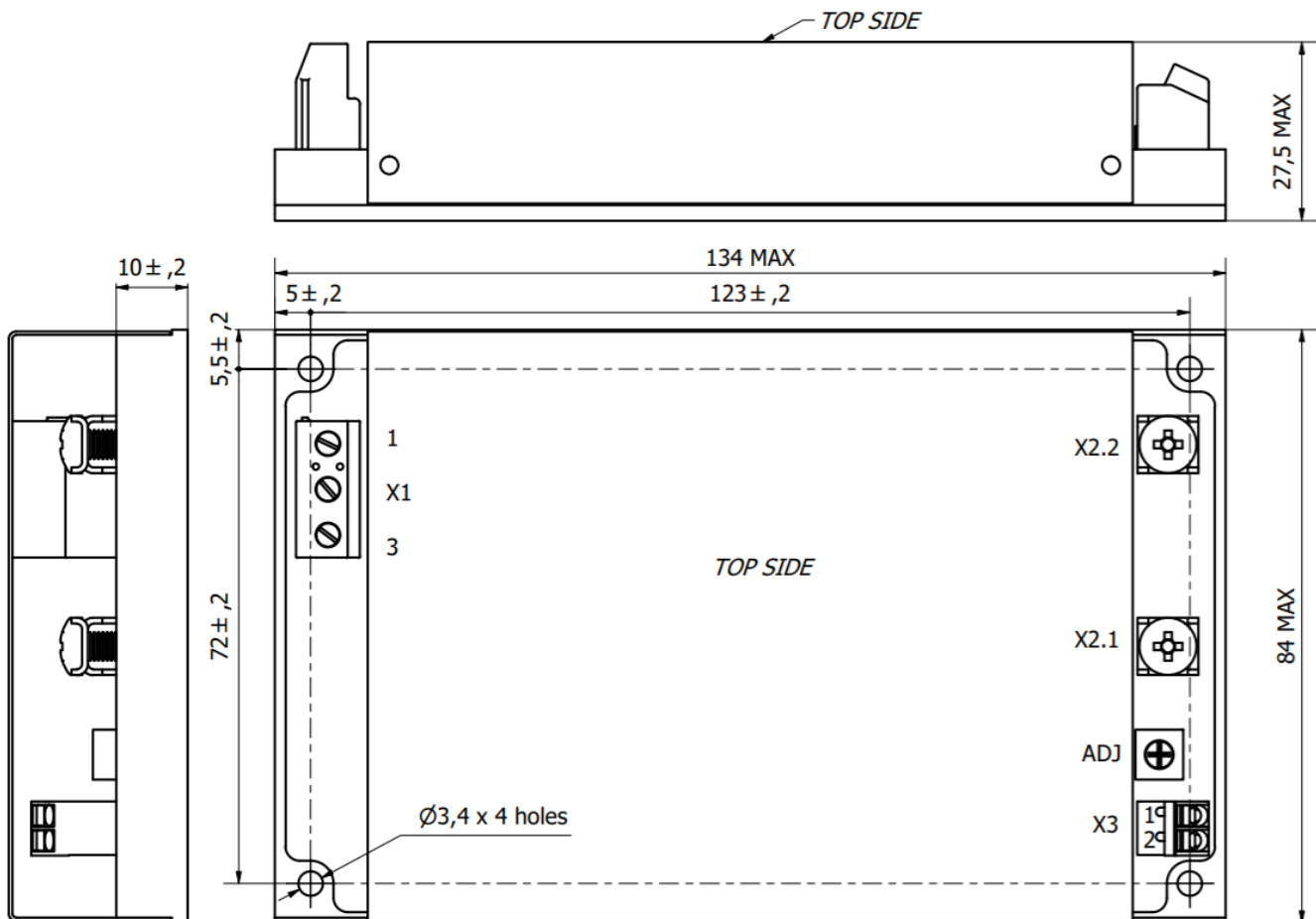

## Dual output

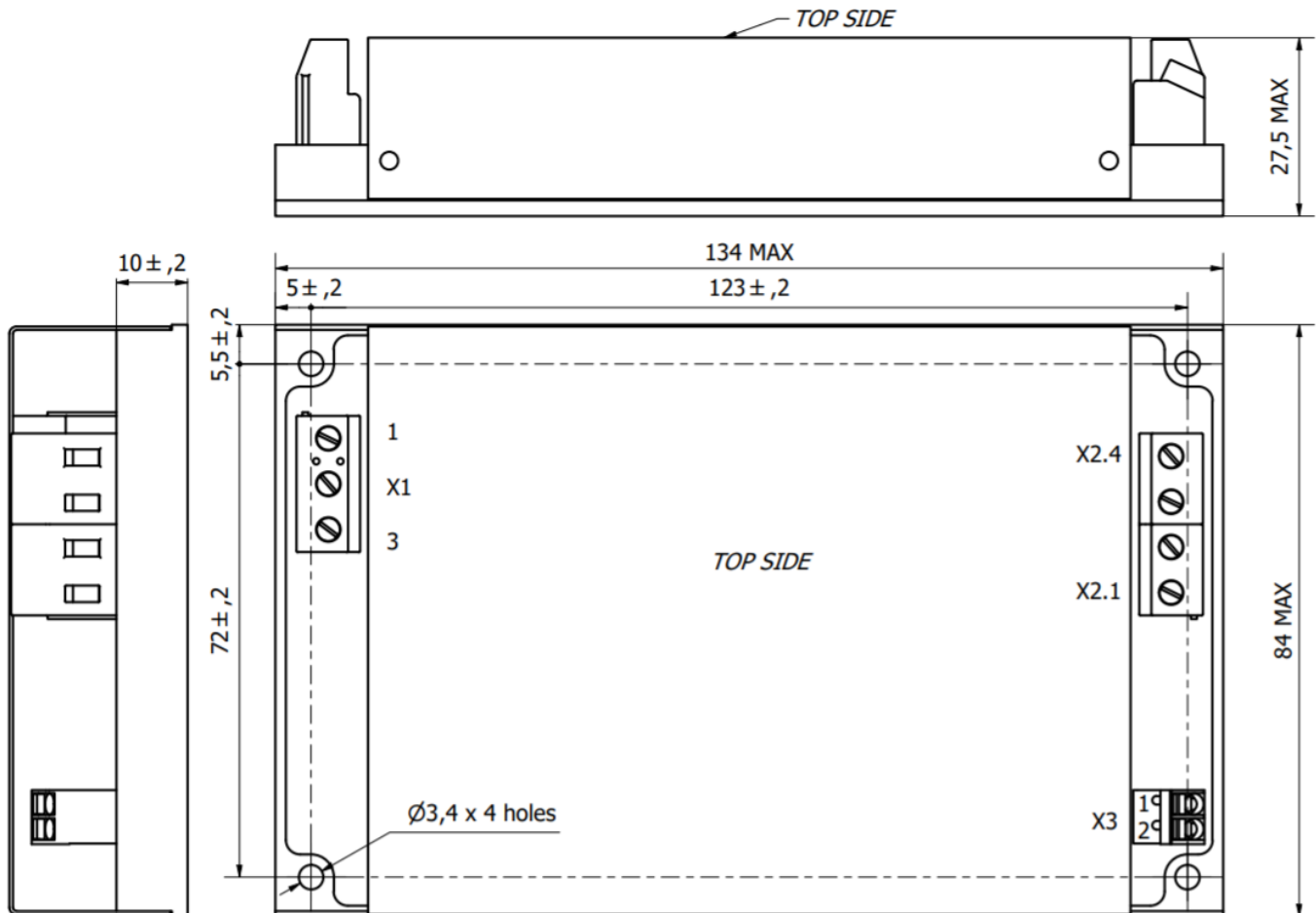

## Additional information

After ordering the product - the customer is fully responsible for applying the product in strict compliance with mentioned rules and principles of use in the product datasheet and reference technical material (RTM) which is downloadable at [www.aeps-group.com](http://www.aeps-group.com).

Please, note that all information in this material is for reference only. Further detailed information (including: additional requirements, manuals and circuit schemes) is found at [www.aeps-group.com](http://www.aeps-group.com) or provided via an email request at [aeps@aeps-group.cz](mailto:aeps@aeps-group.cz). All pictures shown are for illustration purpose only, actual product appearance may vary, incl. inner components choice and placement and connectors placement.

According to company's policy in view of constant improvements of the production design the manufacturer reserves the right to change the contents of specifications and promotional materials without prior notice! Make sure you are using the latest documentation downloadable at [www.aeps-group.com](http://www.aeps-group.com).

© «AEPS-GROUP». All rights reserved.